

GREAT QUALITY FOOD, **FAST**

CiBO





Great quality food. **Fast.**

Café & Bar

- Create or expand your food offer, bring inspiration to your menu, increase profits.
- Produce high-quality food all day – from breakfast and brunch, to lunch and afternoon tea.
- Serve snacks and smaller items with speed – toasted sandwiches, paninis, pizzas and baked goods, such as pastries and muffins.
- A stylish solution for front-of-house – available in four vibrant colours or classic stainless steel, there's a Cibò to suit any café or back bar.

Convenience & Quick Serve

- Open up your takeaway food offer, generate new 'grab and go' business, broaden revenue streams.
- Deliver tasty, high-quality food, consistently, at every order.
- Create a wide range of snacks and baked goods quickly and easily, from a space-saving single appliance.
- Plug in and go – with clear icons and an easy touchscreen, Cibò can be used by anyone, regardless of catering experience and skills.

Restaurant & Hotel

- Develop creative, customised menus, broaden your dishes, deliver consistent quality.
- Produce small lunch items and snacks, such as sandwiches and paninis, alongside main meals – with no interruption to your main cookline.
- Space-saving and compact, Cibò is simple to use – clear icons and an easy-to-use touchscreen can be operated by any kitchen staff, regardless of training and skills.
- Simple to use, out of hours to support room service menu offering.

Event & Mobile Catering

- Create cutting-edge, creative menus, deliver consistent high quality, drive profits.
- Carry out event catering with ease – compact, space saving, ventless and operating from a 13-amp plug, Cibò is perfect for street food outlets and markets.
- Get fancy with your food – Cibò's versatility means a wide range of fresh and frozen foods can be cooked, toasted or reheated. Try new things – be inspired.



Patent Pending Innovation

Cutting-edge, Patent Pending multi-heat innovation is unique (an industry first), delivering great quality food, every time.



Fast - have a need for speed?

CiBO is super fast, producing multiple high-quality menu items in 2-3 minutes.*



Versatile - cook, toast, reheat

CiBO can do it all, with both fresh and frozen foods. Replace your panini grill, toaster, convection oven and grill with a single CiBO unit.



Compact and ventless

CiBO makes life simple. Just plug in and switch on - job done.



2 Year

UK parts & labour warranty

Export parts warranty

Simplicity is at the heart of Cibo.

Simple food icons make it easy to use and overcome any language barriers. Choose a dish, press play and Cibo will do the rest.



Optimising your Cibo

Get personal with your Cibo. Fine-tune it, tailor it and mould it for your menus.

There are two levels to optimising your Cibo. The first is to simply tweak its existing pre-programmed settings to suit you. Whether you want your pizzas more soft and doughy, or your toasties more golden, it's easy to tailor the standard settings to produce the perfect food for your outlet.

When it comes to creating something new with Cibo, the world is your oyster. In addition to fine-tuning pre-set menu items, Cibo allows chefs to get creative and push boundaries, by developing their own bespoke menu programmes.

This optimisation makes it easy for staff of all skill levels to use Cibo. They can create perfectly-cooked, high-quality food, time after time.

Many menu items and settings to choose from

Cibo has the space for up to 24 cook programmes, including 11 pre-programmed menu items. Colour icons are the perfect solution for outlets with extensive menus. Operators can group together items that are cooked in the same way and assign them a specific cook programme and colour – creating a simple system for all staff and skill levels.



Features

Ventless Cooking

Catalyst technology removes need for extraction

USB for software updates

620mm
(inc. handle)

440mm

4.3" Touch Screen Controller

Plug & Play

Phased to give optimal results whilst working on a 3 pin 3kW UK plug

370mm

Compact

Patent pending 3 element cooking system

- 2.4kW grill
- 1.8kW convection heat
- 0.7kW radiant base element ceramic glass cooking area

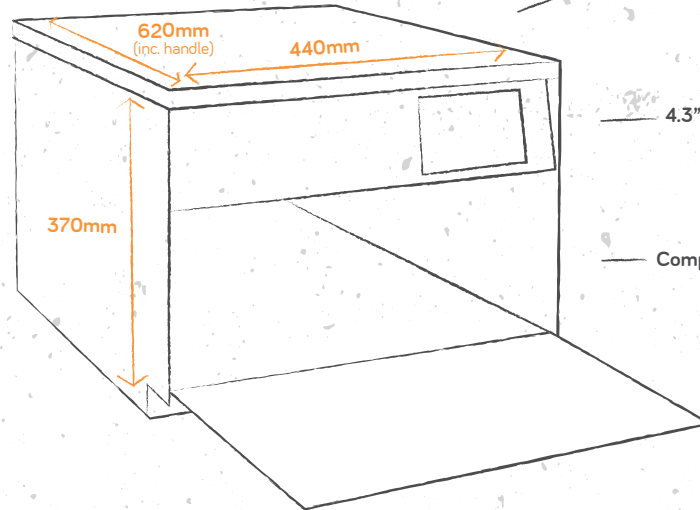

How does it work?

Cibo uses a patent pending combination of three different heat sources – convection, grill and a heated base.

Phased cooking programmes enable each of the three heat sources to switch on and off during the cook cycle to deliver fast results. This produces high-quality, perfectly-cooked food in 2-3 minutes.

Five colours to choose from



Teal



Stainless Steel



Black Metallic



Champagne



Merlot

From vibrant street food vans, to sophisticated rustic restaurants, Cibo is at home anywhere.

Available in four bold colours (black metallic, champagne, merlot and teal), as well as sleek stainless

steel, there's a Cibo for all catering settings – whether it's on a front-of-house counter, or tucked away in a kitchen.

Choose a Cibo to complement your outlet's style.



Getting started with your Cibo

Simplicity is at the heart of Cibo. To demonstrate how easy it is to achieve high-quality food and healthy profit opportunities, we've filmed it in action – using our favourite recipes.

Why not take a look for yourself at:

www.youtube.com/@LincatLtd/videos

The videos showcase the straightforward journey for users – via the Cibo's intuitive touchscreen and simple icons. Just select an option – and the Cibo will do the rest.



USP's

- Crisp baked pizza base
- No microwave technology which can cause sogginess

Cibo Settings



Pizza

Cook Time:
0:03:25

12 Months Profit Opportunity

£12,532

Cost per serving: £1.85

Average Selling Price: £8.01 (Incl. VAT)

Profit per serving: £4.82

50 serving per week: £241.00



Club Sourdough Sandwich

USP's

- Does not squash sandwich
- Toasts base
- Bread is toasted not microwaved

Cibo Settings



Toasted Sandwich

Cook Time:

0:01:10

12 Months Profit Opportunity

£8,320

Cost per serving: £1.38

Average Selling Price: £5.50 (Incl. VAT)

Profit per serving: £3.20

50 serving per week: £160.00



Breakfast Bap

USP's

- Cook everything at once

Cibo Settings



Eggs & Bacon

Cook Time:

0:01:10

12 Months Profit Opportunity

£2,964

Cost per serving: £1.14

Average Selling Price: £2.73 (Incl. VAT)

Profit per serving: £1.14

50 serving per week: £57.00





USP's

- Evenness on bake

Cibo Settings



Croissants

Cook Time:

0:16:10

12 Months Profit Opportunity
£2,314

Cost per serving: £0.36

Average Selling Price: £1.50 (Incl. VAT)

Profit per serving: £0.89

50 serving per week: £44.50



Reuben Panini

USP's

- No squished paninis
- Cook multiples without additional cooking time
- Faster than a traditional panini press

Cibo Settings



Panini

Cook Time:

0:02:30

12 Months Profit Opportunity
£5,850

Cost per serving: £1.04

Average Selling Price: £3.95 (Incl. VAT)

Profit per serving: £2.25

50 serving per week: £112.50



Nachos

USP's

- No more soggy nachos
- Nachos remain crisp without microwave technology

Cibo Settings



Nachos

Cook Time:

0:01:30

12 Months Profit Opportunity
£8,580

Cost per serving: £1.66

Average Selling Price: £5.95 (Incl. VAT)

Profit per serving: £3.30

50 serving per week: £165.00



Cookies

USP's

- No need for separate oven

Cibo Settings



Cookies

Cook Time:

0:16:00

12 Months Profit Opportunity
£1,872

Cost per serving: £0.32

Average Selling Price: £1.25 (Incl. VAT)

Profit per serving: £0.72

50 serving per week: £36.00



Halloumi Kebab

USP's

- No need for a separate grill, griddle or chargrill

Cibo Settings



Kebabs

Cook Time:

0:03:50

12 Months Profit Opportunity
£4,615

Cost per serving: £2.70

Average Selling Price: £7.50 (Incl. VAT)

Profit per serving: £3.55

25 serving per week: £88.75



Pancakes & Waffles

USP's

- Heat pancakes through without drawing out moisture
- No more soggy reheated pancakes

Cibo Settings



Pancake/Waffles
Heat Up

Cook Time:

0:02:10

12 Months Profit Opportunity
£4,186

Cost per serving: £0.85

Average Selling Price: £2.95 (Incl. VAT)

Profit per serving: £1.61

50 serving per week: £80.50



Hotdog

USP's

- No need for a separate hob

Cibo Settings



Hotdogs

Cook Time:
0:07:05

12 Months Profit Opportunity

£3,900

Cost per serving: £0.58

Average Selling Price: £2.50 (Incl. VAT)

Profit per serving: £1.50

50 serving per week: £75.00



Muffins

USP's

- No need for separate oven

Cibo Settings



Muffins

Cook Time:
0:20:00

12 Months Profit Opportunity

£3,250

Cost per serving: £0.38

Average Selling Price: £1.95 (Incl. VAT)

Profit per serving: £1.25

50 serving per week: £62.50



What's in the box?

Cibo

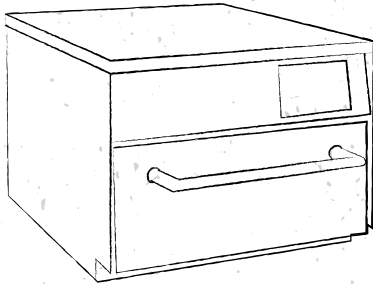

Paddle (CIBO/LT)



Baking Tray (CIBO/BT)

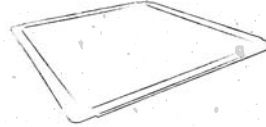

USB Stick



Wire Rack (SH136)



Teflon Sheet (TFS05)

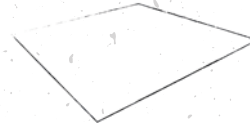

Available Accessories

Wall Bracket (CIBO/WB)



Stacking Kit (CIBO/SK)



Plinth (CIBO/PL)





The Face of Cibo

Sophie Piccirilli

I have been blessed with a big, beautiful family and my childhood memories are filled with the tastes and aromas of my Nonna's cooking. I would watch on, as she lovingly created her delicious authentic Italian food, closely following recipes and traditions handed down by previous generations, with the sole aim of pleasing her family. She's truly the most talented and inspirational woman in my life.

The Piccirillis express their love through food, we aren't always great at verbalising emotions, and so what's on the plate does the talking!



Every year we would visit our family holiday home in a small village called Sassofeltrio, perched on a rock in the culinary region of Le Marche. There is one local restaurant called Savioli's, which I affectionately have christened 'Luciano's', after its proud owner. On my holidays, I spent time with Luciano and his family in the kitchen, as they took me under their wing. Two hundred eggs are used every morning, just to make fresh pasta, of all varieties (my favourite being 'Strozzapreti'... look up the translation!) This mesmerised me, such a small village, full of happy and contented people, with no desire for wealth or



stature. Watching elderly women, knead and shape individual pastas, spurred me on to do the same. I was incredibly lucky to experience such talent; I absorbed so much.

Now at 22 years old, my whole working experience has been in catering. I have run my own business as well as working in high end restaurants and bars, making everything from purees, sorbets, souffles, parfais, cocktails, to all kinds of freeze dried fruits and a wide variety of breads.

For me, eating is an experience, allowing people to talk and share, introducing new flavours to one

another. I often struggle to choose one dish from a menu, so my philosophy is why choose one, when you can try a little bit of everything? I now want to share my experiences, giving everyone the opportunity to enjoy a range of food dishes, through a variety of tastes and flavours.

I truly live to eat rather than eat to live - my motto being "Vivere per Mangiare!"

CiBO

Tel UK: +44 (0)1522 875500
Tel Export: +44 (0) 1522 503250
Email: sales@lincat.co.uk

lincat.co.uk

