



## FRIFRI ECO 6 ELECTRIC COUNTER-TOP SINGLE TANK FRYER - 1 BASKET - W 254 MM - 3.2 KW

# MODEL: 650105



Minimum space, maximum output. The FriFri 3.2kW Eco 6 Counter Top Fryer won't take up much space on your worksurface, but it will deliver when you need it to. Sturdy, with a stainless steel tank for easy cleaning, it's ideal for any venue where chips and other highly-flavoured fried foods are required. Equipped with a mechanical thermostat for maintaining oil temperature, the Eco 4 boasts the kind of quality that customers have come to expect from the FriFri brand for over 70 years.

### PRODUCT OPTIONS AND ACCESSORIES

- FZ300942 BASKET FOR ECO 6 MODELS - COMPLETE WITH MOULDED HANDLE

### PRODUCT FEATURES

- Ideal for the supply of portions of chips, as an occasional fryer or for cooking highly flavoured food
- Mechanical thermostat for maintaining oil temperature to within +/-8 °C of the temperature set
- One piece pressed stainless steel tank with rounded corners and lift-out control panel for reduced cleaning times

A/A FILE NUMBER:

ITEM NUMBER:



# FRIFRI ECO 6 ELECTRIC COUNTER-TOP SINGLE TANK FRYER - 1 BASKET - W 254 MM - 3.2 KW

## MODEL: 650105

### WEIGHTS & DIMENSIONS

Width	254 mm
Depth	375 mm
Height	295 mm
Weight	5.3 kg

### SHIPPING DETAILS

Ship Width	42 cm
Ship Depth	27 cm
Ship Height	33 cm
Ship Weight	5.83 kg
Number of Shipment Parcels	1
Shipping Origin Zip Code	LN6 3QZ, UNITED KINGDOM
Quick Ship Product	No
Returnable Item	No

### PRODUCT CERTIFICATIONS



### ENERGY SPECS

Primary Energy Source Type	Electricity	Number of Electrical Conductor Wires	1
Electrical Amps	13.9	Electrical Connection Type	Direct Hardwired
Electrical Voltage	230 volts	Electrical Plug Type	Hardwired
Electrical Watts	3,200	Number of Electrical Plugs	Not Applicable
Electrical Phase	Single	Dedicated Circuit Required	Yes
Kilowatts	3.2 kW	Energy Saving	No

### ADDITIONAL SPECIFICATIONS

Auto Oil Top-Off	No	Total Oil Capacity (volume)	10 l
Basket Lift Type	Not Applicable	Oil Reclamation	No
Control Type	Rotary Control Knob	Oil Temperature Control	Mechanical
Food Production Rate	7kg fries - 7mm [frozen]	Pumped Oil Filtration	No
Fryer Type	Open Pot	Split Pot	No
Integrated Filtration	No	Temperature Maximum	190 °C
Number of Baskets	1	Temperature Minimum	100 °C
Number of Burners	Not Applicable	Vat 1 Oil Capacity (volume)	10 l
Number of Vats (batteries)	1		

FriFri reserves the right to modify specifications or discontinue models without incurring obligation. Dimensions nominal.

Document Auto-Generated  
January 23, 2024





FRIFRI ECO 6 ELECTRIC COUNTER-TOP SINGLE TANK FRYER - 1  
BASKET - W 254 MM - 3.2 KW

MODEL: 650105

**BIDDING SPECIFICATIONS**

Bidding Specifications Not Available.

**TECHNICAL DRAWING**

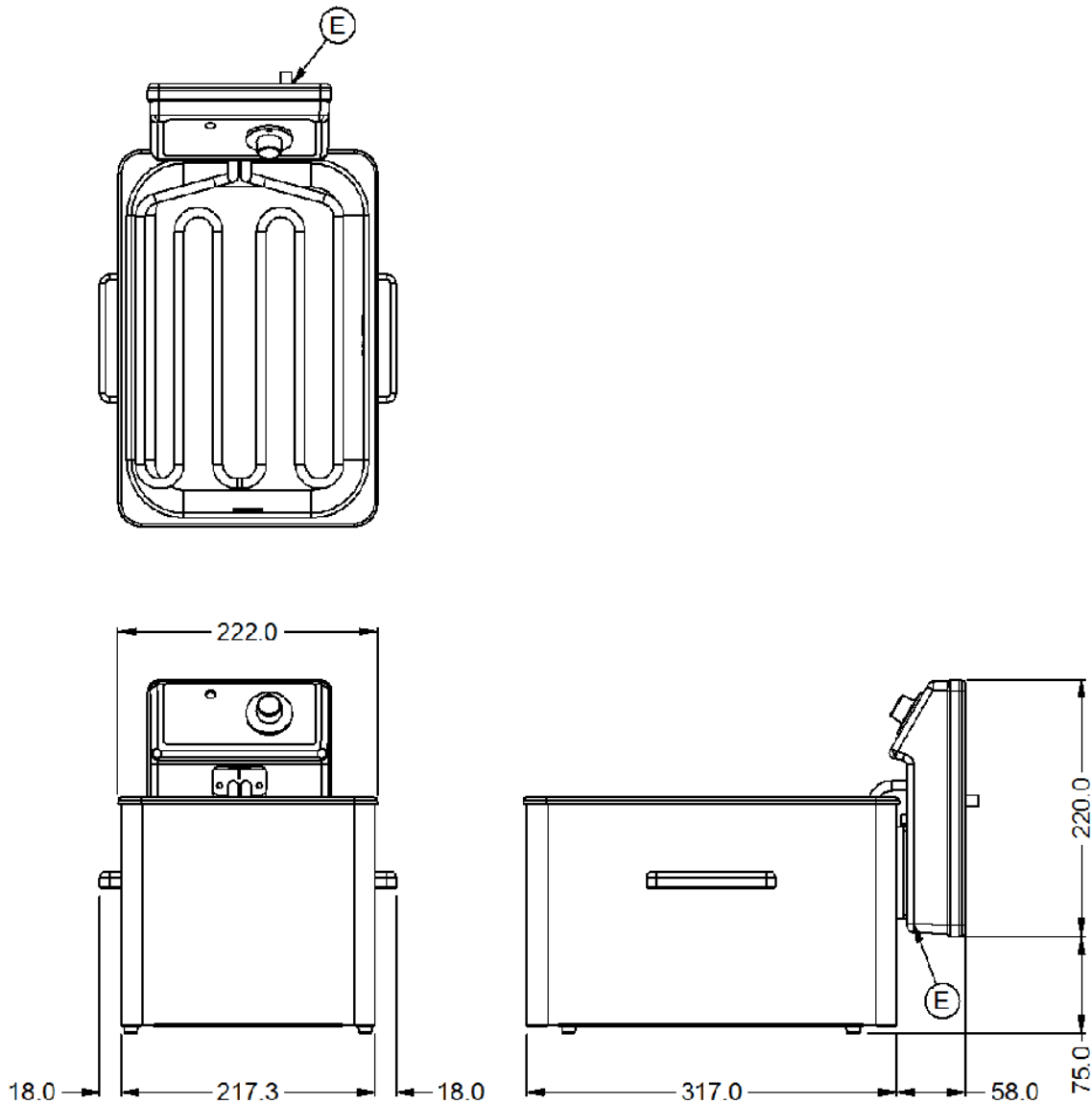

Frifri reserves the right to modify specifications or discontinue models without incurring obligation. Dimensions nominal.

Document Auto-Generated  
January 23, 2024

