



FriFri Super Easy 211 Electric Free-standing Single Tank Fryer - W 200mm



Super Easy offers all the benefits you would expect from a FriFri fryer, reliable, efficient performance that delivers consistently excellent fried food.

Super Easy offers outstanding value with no compromise in quality or performance.

- ✓ Outstanding value with no compromise in quality or performance.
- ✓ High output from minimal space.
- ✓ Mechanical thermostat maintains oil to within +/-8 °C of the temperature selected.
- ✓ Pressed tank for strength and durability. Radiused corners for easy cleaning. Hinged elements with two tilt positions for draining and cleaning.
- ✓ Keeping your oil in peak condition! Can be supplied with integral gravity filtration extends oil life by up to 75% saving you money on oil purchase and disposal costs. Optional xFri® filters the oil at the push of a button and returns oil to the tank. Filter the oil safely, even while it's still hot, mid service if necessary, and resume frying in minutes – so easy there is no excuse not to!

As standard



Thermostatic Temperature Control



Rotary Control Front

Optional



Gravity-fed Oil Filtration



xFri® Pumped Oil Filtration Option

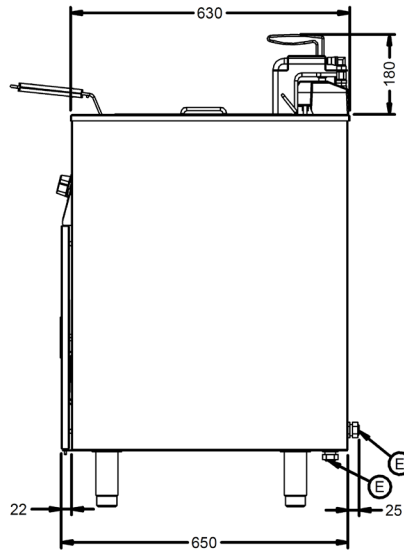
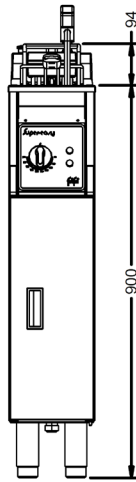
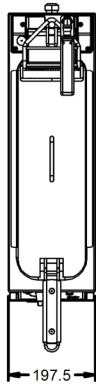

Fryer Designer

Please use our Fryer Designer to create your bespoke code.

Do you want an alternative configuration of baskets?

How many supply cables would you like?

Do you require chargeable add on items such as castors and pumped oil filtration?

Range	Base Mounting	Fryer Width	Number Of Tanks	Number Of Baskets	Element Power	Phase	Cables	Filtration / Pumps	Number of Basket Lifts
Super Easy	Legs	200mm	1	1	Low 7.5 kW High 11.0 kW	1 - 230V 1 NAC 3 - 400V 3 NAC 5 - 230V 1 AC 6 - 230V 3 AC 7 - 400V 3 AC 8 - 440V 3 AC	1	No Filtration Gravity Filtration 1 Pump	0

If you would like help to create code please call us on 01522 875500.



Friteuse électrique sur coffre FriFri Super Easy 211 à cuve simple - L 200 mm



La Super Easy vous offre tous les avantages que vous attendez d'une friteuse FriFri, une performance efficace qui permet de produire d'excellents aliments frits de manière régulière.

La Super Easy offre un rapport qualité-prix exceptionnel, sans compromis sur la qualité ou les performances.

- ✓ Une qualité et une performance inégalées, pour un excellent rapport qualité-prix.
- ✓ Un rendement élevé pour un minimum d'espace.
- ✓ Un thermostat mécanique maintient l'huile à +/- 8 °C de la température sélectionnée.
- ✓ Cuve pressée pour plus de robustesse et de durabilité. Coins arrondis pour un nettoyage facile. Éléments articulés avec deux positions d'inclinaison pour la vidange et le nettoyage.

- ✓ Gardez votre huile en condition optimale ! Peut être équipée d'une filtration par gravité intégrée, ce qui prolonge la durée de vie de l'huile de près de 75 %, et permet de réaliser des économies sur les coûts d'achat et d'élimination. La xFri® en option filtre l'huile d'une simple pression sur un bouton et renvoie l'huile vers la cuve. Filtrez l'huile en toute sécurité, même lorsqu'elle est encore chaude, entre les cuissons si nécessaire, et reprenez la friture en quelques minutes - tellement facile qu'il n'y a aucune excuse pour ne pas le faire !

En standard



Commande thermostatique de température



Commande rotative avant



Filtration d'huile alimentée



Filtration xFri® d'huile pompée

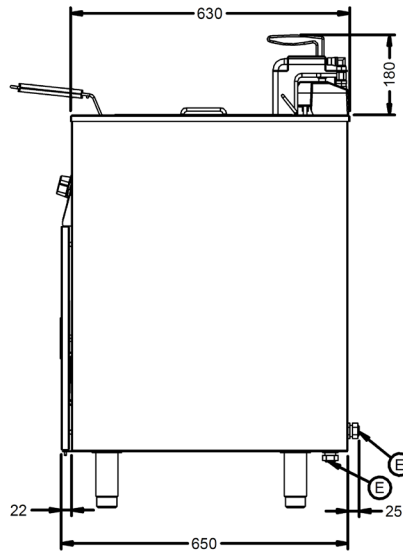
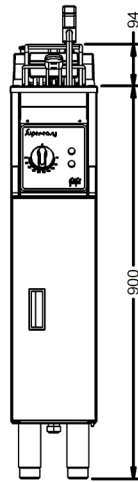
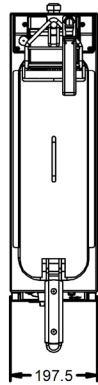

Concepteur de friteuses

Utilisez notre concepteur de friteuses pour créer votre code sur mesure.

Souhaitez-vous une autre configuration pour les paniers ?

Combien de câbles d'alimentation voulez-vous ?

Avez-vous besoin d'articles payants supplémentaires comme des roulettes et une filtration de l'huile pompée ?

Gamme	Socle de montage	Largeur de la friteuse	Nbre de cuves	Nbre de paniers	Puissance de l'élément	Phase	Câbles	Filtration / Pompes	Nbre de relevages
Super Easy	Pieds	200 mm	1	1	Faible 7,5 kW Élevée 11,0 kW	1- 230V 1 NAC 3- 400V 3 NAC 5- 230V 1 AC 6- 230V 3 AC 7- 400V 3 AC 8- 440V 3 AC	1	Aucune filtration Filtr. par gravité 1 Pompe	0

Si vous avez besoin d'aide pour créer le code, appelez-nous au 01522 875500.

DE

FriFri Super Easy 211 Elektrische freistehende Fritteuse mit einem Becken - B 200 mm



Die Super Easy bietet alle Vorteile, die Sie von einer FriFri Fritteuse erwarten können: verlässliche, effiziente Leistung, die durchgehend ausgezeichnete frittierte Gerichte liefert.

Die Super Easy bietet hervorragenden Wert, ohne Abstriche bei Qualität oder Leistung.

- ✓ Hervorragender Wert, ohne Abstriche bei Qualität oder Leistung.
- ✓ Hohe Leistung bei minimalem Platzbedarf.
- ✓ Mechanischer Thermostat garantiert, dass die Öltemperatur maximal +/- 8 °C von der ausgewählten Temperatur abweicht.
- ✓ Gepresstes Becken für Festigkeit und Haltbarkeit. Abgerundete Ecken für eine einfache Reinigung. Klappbare Elemente mit zwei Kippstellungen zum Entleeren und Reinigen.
- ✓ So bleibt Ihr Öl in Topform! Kann mit integrierter Schwerkraftfiltration geliefert werden, die die Lebensdauer des Öls um bis zu 75 % verlängert. Dadurch sparen Sie Kosten für den Einkauf und die Entsorgung von Öl. Optionaler xFri®-Filter filtert das Öl auf Knopfdruck und führt Öl in das Becken zurück. Sie können das Öl auch heiß sicher filtern, falls nötig während der Verwendung, und in unter fünf Minuten wieder mit dem Frittieren beginnen!

Standardmäßig



Thermostatische Temperaturregelung



Drehknöpfe vorn

Optional



Ölfiltration durch Schwerkraft



xFri® Ölpumpfiltersystem

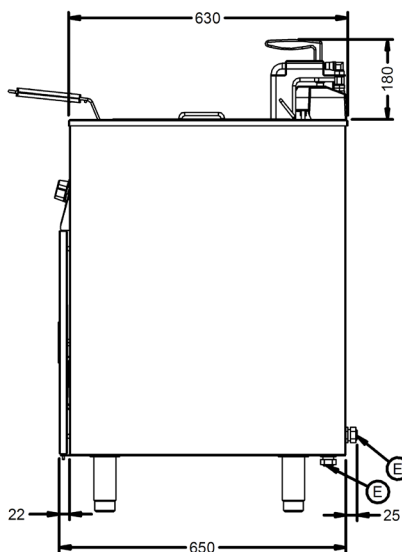
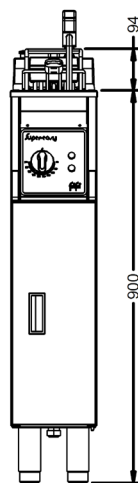
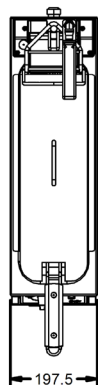

HxWxD
986x197,5x650



39



Elektroanschluss

Fritteusendesigner

Bitte verwenden Sie unseren Fritteusendesigner, um Ihren individuellen Code zu erstellen.

Möchten Sie eine andere Korbkonfiguration?

Wie viele Versorgungskabel brauchen Sie?

Brauchen Sie kostenpflichtige Zusatzausstattungen wie Rollen oder Ölpumpfiltersystem?

Produktlinie	Montage des Untergestells	Fritteusenbreite	Anzahl Becken	Anzahl Körbe	Leistung Heizelement	Phase	Kabel	Filtration/ Pumpen	Anzahl Korbhebungen
Super Easy	Beine	200 mm	1	1	Niedrig 7,5 kW Hoch 11,0 kW	1 - 230V 1 NAC 3 - 400V 3 NAC 5 - 230V 1 AC 6 - 230V 3 AC 7 - 400V 3 AC 8 - 440V 3 AC	1	Keine Filtration Schwerkraftfiltr. 1 Pumpe	0

Wenn Sie Hilfe bei der Erstellung des Codes benötigen, rufen Sie uns bitte unter 01522 875500 an.



Friggitrice elettrica con mobile serbatoio singolo FriFri Super Easy 211 - W 200mm



La gamma Super Easy offre tutti i vantaggi che ci si aspetta da una friggitrice FriFri, nonché prestazioni affidabili ed efficienti che garantiscono la preparazione di cibi fritti sempre eccellenti.

Offre un valore straordinario senza alcun compromesso in termini di qualità o prestazioni.

- ✓ Valore straordinario senza alcun compromesso in termini di qualità o prestazioni.
- ✓ Risultati straordinari in uno spazio minimo.
- ✓ Il termostato meccanico mantiene la temperatura dell'olio entro +/-8 °C rispetto alla temperatura selezionata
- ✓ Serbatoio compresso per ottimizzare resistenza e durata. Spigoli a raggiera per facilitare la pulizia. Elementi incernierati con due posizioni di inclinazione per scarico e pulizia.
- ✓ Olio mantenuto in condizioni ottimali! Può essere dotata di sistema di filtraggio integrale che aumenta la durata dell'olio fino al 75% con conseguente risparmio sull'acquisto dell'olio e riduzione dei costi di smaltimento. Con la semplice pressione di un pulsante, il sistema xFri® optional filtra l'olio e lo riconvoglie nel serbatoio. In questo modo, l'olio viene filtrato in sicurezza, persino quando è ancora bollente (anche a metà servizio, se necessario) e la friggitrice si riattina in pochi minuti, per cui non ci sono scuse!

Standard



Controllo termostatico della



Parte frontale del comando a rotazione

Optional



Filtraggio dell'olio per gravità



Filtraggio dell'olio tramite pompa xFri®

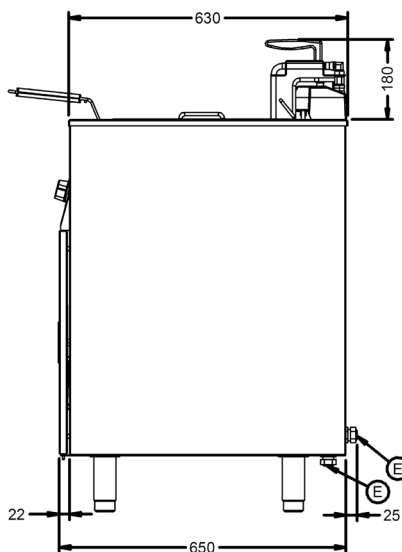
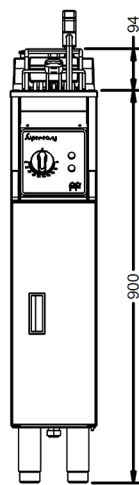
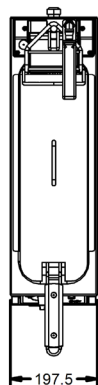

HxWxD
986x197,5x650



39



Alimentazione elettrica

Designer delle friggitrici

Utilizzate il Designer delle friggitrici per creare il vostro codice su misura.

Siete interessati a una configurazione alternativa dei cestelli?

Quanti cavi di alimentazione sono necessari?

Siete interessati ad articoli aggiuntivi a pagamento come rotelle o filtraggio dell'olio a pompa?

Gamma	Montaggio base	Larghezza friggitrice	Numero di serbatoi	Numero di cestelli	Potenza Potenza	Fase	Cavi	Filtraggio/ Pompe	Numero di sollevamenti cestello
Super Easy	Piedini	200mm	1	1	Basso 7,5 kW Alto 11,0 kW	1 - 230V 1 NAC 3 - 400v 3 NAC 5 - 230V 1 AC 6 - 230V 3 AC 7 - 400V 3 AC 8 - 440V 3 AC	1	Nessun filtr. Filtr. per gravità 1 Pompa	0

Per farlo, potete contattarci al numero 01522 875500.

ESP

Freidora eléctrica independiente con un depósito 211 Super Easy Frifri - 200 mm de ancho

La gama Super Easy ofrece todas las ventajas que se pueden esperar de una freidora FriFri: un rendimiento fiable y eficiente que proporciona una fritura siempre excelente.

Super Easy garantiza un valor excepcional sin poner en riesgo ni la calidad ni el rendimiento.



- ✓ Valor excepcional sin poner en riesgo ni la calidad ni el rendimiento.
- ✓ Máximo rendimiento en un espacio mínimo.
- ✓ Termostato mecánico que mantiene la temperatura del aceite dentro de un margen de +/-8 °C de la temperatura fijada.
- ✓ Depósito prensado para mayor resistencia y durabilidad. Esquinas redondeadas para facilitar la limpieza. Elementos abatibles con dos posiciones de inclinación para el correcto drenaje y limpieza.
- ✓ ¡Mantenga el aceite en las condiciones óptimas! El sistema opcional de filtración integral por gravedad aumenta la vida útil del aceite hasta en un 75 %, por lo que ahorra dinero tanto en la compra de aceite como en los costes de eliminación. Con solo pulsar un botón, el sistema opcional xFri® filtra el aceite usado y devuelve el aceite limpio al depósito. Esto le permite filtrar el aceite de forma segura, incluso mientras está caliente o a mitad de servicio si es necesario, y volver a freír en minutos. ¡Es tan fácil que no hay excusa para no hacerlo!

De serie



Control termostático de la temperatura



Parte delantera de control

Opcional



Filtración de aceite por gravedad



Filtración de aceite por bombeo xFri®

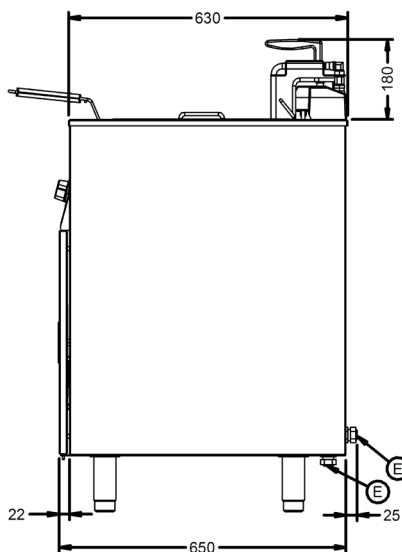
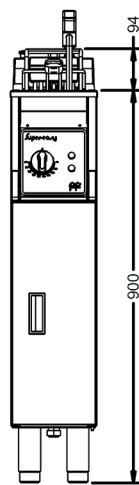
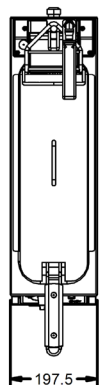

HxWxD
986 x 197,5 x
650



39



Suministro
eléctrico

Diseñador de freidoras

Utilice nuestro diseñador de freidoras para crear su modelo a medida.

¿Quiere una configuración alternativa de las cestas?

¿Cuántos cables de alimentación quiere?

¿Necesita elementos adicionales de pago, como ruedas y filtración de aceite por bombeo?

Rango	Montaje de la base	Ancho de la freidora	Número de depósitos	Número de cestas	Potencia del elemento	Fase	Cables	Filtración / Bombas	Número de elevaciones de cesta
Super Easy	Patas	200 mm	1	1	Baja 7,5 kW Alta 11,0 kW	1 - 230 V 1 CD 3 - 400 V 3 CD 5 - 230 V 1 CA 6 - 230 V 3 CA 7 - 400 V 3 CA 8 - 440 V 3 CA	1	Sin filtración Filtr por gravedad 1 bomba	0

Si quiere que le asesoremos, llámenos al 01522 875500.