



SP
PEELER

PRODUCT OPTIONS AND ACCESSORIES

- S58/568 Filter Basket - Integral - for SP Potato Peeler
- S58/569 Interceptor Tank - for SP Potato Peeler [pedestal mounted/2" BSP]
- A29/003 Lid Retaining Strap for SP/VQ Potato Peeler
- S58/570 Waste Ejector for SP Potato Peeler [2" BSP]

With a small footprint and quiet motor, the energy-efficient SP25 (3PH) peeler is ideal for medium and large kitchens with a three-phase power supply. Offering the speed and convenience of pre-prepared products, it has the power to peel up to 25kg of vegetables in two minutes - up to 513kg per hour - saving space and time.

Simple and safe to operate, the floor-standing SP25 (3PH) has a high pedestal, allowing the unit to be emptied into a sink.

Constructed from rust-proof stainless steel, the SP25 (3PH) is robust and low maintenance, with a heavy-duty belt and pulley drive. Its corrosion-

PRODUCT FEATURES

- Able to peel 25kg of potatoes in 2 minutes - up to 513kg per hour
- Upright design with small footprint, ideal for medium and large operations
- High pedestal makes unit the perfect height to empty into a sink
- Lubricated, heavy-duty gearbox makes peeling operation smooth and reliable
- Dual position waste outlets and smooth cylinder base for quick, easy cleaning
- Long-lasting, rust-proof plate and replaceable liners for effective peeling
- Suitable for kitchens with three-phase power supply
- WRAS-approved Class A air-break and brass spray nozzle to prevent water escape



WEIGHTS & DIMENSIONS

Width	603 mil
Depth	728 mil
Height	1357 mil
Weight	68 kg

SHIPPING DETAILS

Ship Width	79 cm
Ship Depth	65 cm
Ship Height	155 cm
Ship Weight	74.8 kg
Number of Shipment Parcels	1
Ship Method	Small Parcel (FedEx, UPS, DHL)
Shipping Origin Zip Code	LN6 3QZ, UNITED KINGDOM
Quick Ship Product	No

PRODUCT CERTIFICATIONS



ENERGY SPECS

Primary Energy Type	Electric	Electrical Plug Type	Hardwired
Electrical Total Amperage	2.1 A	Number of Electrical Plugs	Not Applicable
Electrical Volts	400V	Electrical Connection Type	Direct Hardwired
Electrical Total Wattage	750 W	Number of Electrical Conductor Wires	1
Electrical Kilowatts	0.75 kW	Electrical Remarks	Three
Electrical Phase	3-Phase	Energy Saving	No

ADDITIONAL SPECIFICATIONS

Airbreak	Yes
Control Type	On/Off
Hopper Load	25 kg
Motor Power	1 hp
Operator Safety Method	User Guide
Processing Capacity Per Hour	513 kg
Timer Type	Mechanical/Traditional Timer

BIDDING SPECIFICATIONS

Bidding Specifications Not Available.





IMC SP25H FLOOR-MOUNTED POTATO PEELER - 3 PHASE - H 1360
MM - 0.75 KW

MODEL: F58/913

TECHNICAL DRAWING

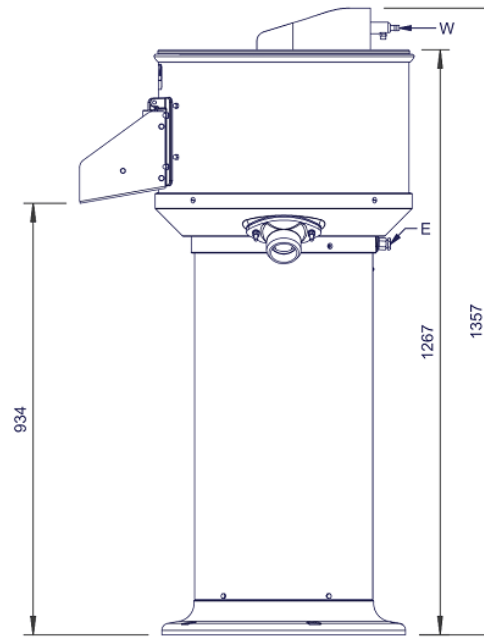
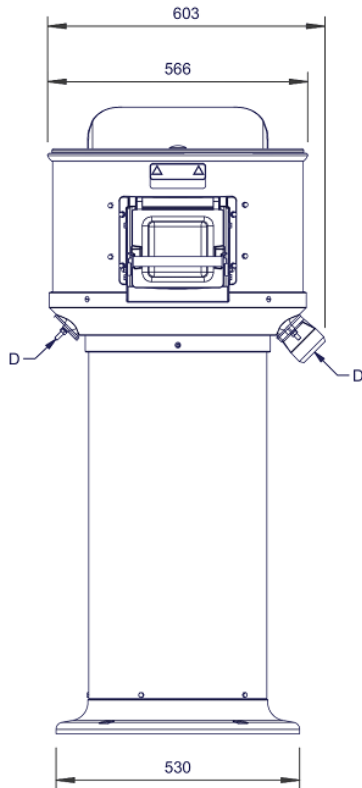
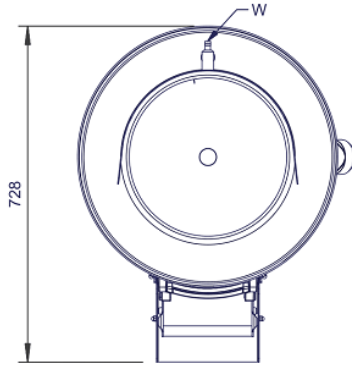

IMC reserves the right to modify specifications or discontinue models without incurring obligation. Dimensions nominal.

Document Auto-Generated
July 02, 2024

