



PRODUCT OPTIONS AND ACCESSORIES

- S59/164 Carborundum Peeling Plate for MF10/MF10L/MF15/MF15L Vegetable Peeler
- S59/168 Knife Peeling Plate for MF10/MF15 Vegetable Peeler
- S59/166 Onion Peeling Plate for MF10/MF15 Vegetable Peeler
- E72/011 Sink Skip - Stainless Steel - for MF10/MF10L/MF15/MF15L/VQ Peeler

The versatile, energy-efficient MF10 (1PH) is a multi-functional peeler which is ideal for medium to large kitchens, with a single-phase power supply. A variety of plate options means it can be used to wash and peel root vegetables, including potatoes and onions, wash mussels, clams and other bivalve shellfish, and spin salads.

With a thicker peeling plate for long operating life, the MF10 (1PH) is able to peel up to 296kg of vegetables per hour in 10kg batches making it a cost-effective and labour-saving solution.

Easy to operate, the unit comes with an integral stand and removable filter basket. It has an

PRODUCT FEATURES

- Able to peel up to 296kg of vegetables per hour - in 10kg batches.
- Versatile - can be used to peel and wash veg and mussels, and spin salad.
- Interlocking lid and door ensure safe operation.
- Perspex viewing pane allows you to monitor the peeling progress.
- Adjustable timer ensures accurate, repeatable peeling times.
- Modular construction facilitates easy maintenance.
- Thicker peeling plate delivers longer operating life.
- Suitable for medium to large kitchens with single-phase power supply.



IMC MF10 FREE-STANDING VEGETABLE PEELER - 1 PHASE - W 481
MM - 0.37 KW

MODEL: F59/510

WEIGHTS & DIMENSIONS

Width	481 mil
Depth	633 mil
Height	1105 mil
Weight	50.5 kg

SHIPPING DETAILS

Ship Width	68 cm
Ship Depth	51 cm
Ship Height	117 cm
Ship Weight	55.55 kg
Number of Shipment Parcels	1
Ship Method	Small Parcel (FedEx, UPS, DHL)
Shipping Origin Zip Code	LN6 3QZ, UNITED KINGDOM
Quick Ship Product	No

PRODUCT CERTIFICATIONS



ENERGY SPECS

Primary Energy Type	Electric	Number of Electrical Plugs	Not Applicable
Electrical Total Amperage	3.6 A	Electrical Connection Type	Direct Hardwired
Electrical Volts	230V	Number of Electrical Conductor Wires	1
Electrical Total Wattage	370 W	Dedicated Circuit Required	Yes
Electrical Kilowatts	0.37 kW	Electrical Remarks	Single
Electrical Phase	1-Phase	Energy Saving	No
Electrical Plug Type	Hardwired		

ADDITIONAL SPECIFICATIONS

Airbreak	Yes
Control Type	On/Off, Rotary Control Knob
Hopper Load	5 kg
Motor Power	0.5 hp
Operator Safety Method	Interlock
Processing Capacity Per Hour	296 kg
Timer Type	Mechanical/Traditional Timer

IMC reserves the right to modify specifications or discontinue models without incurring obligation. Dimensions nominal.

Document Auto-Generated
July 02, 2024



IMC MF10 FREE-STANDING VEGETABLE PEELER - 1 PHASE - W 481
MM - 0.37 KW

MODEL: F59/510

BIDDING SPECIFICATIONS

Bidding Specifications Not Available.

TECHNICAL DRAWING

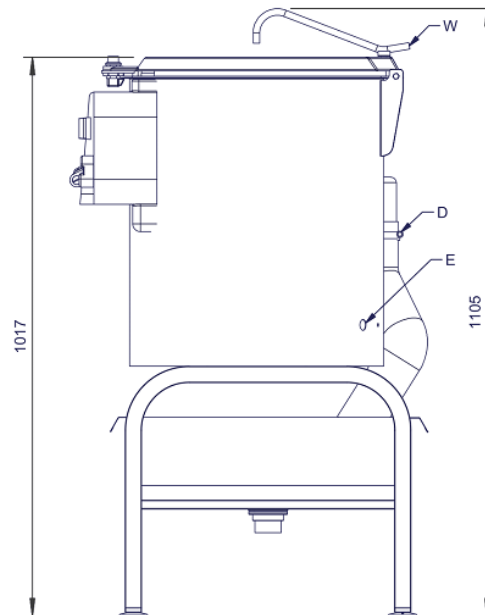
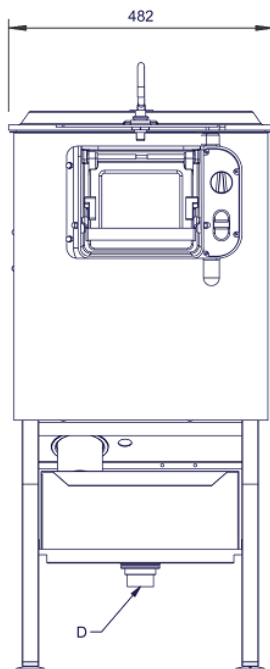
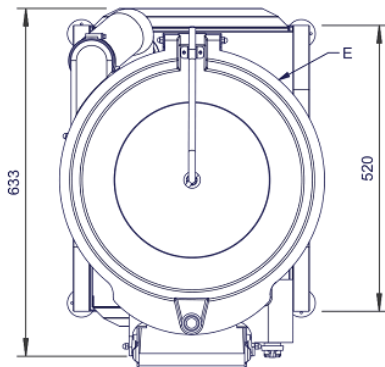

IMC reserves the right to modify specifications or discontinue models without incurring obligation. Dimensions nominal.

Document Auto-Generated
July 02, 2024