



#### PRODUCT OPTIONS AND ACCESSORIES

- S59/164 Carborundum Peeling Plate for MF10/MF10L/MF15/MF15L Vegetable Peeler
- S59/168 Knife Peeling Plate for MF10/MF15 Vegetable Peeler
- S59/166 Onion Peeling Plate for MF10/MF15 Vegetable Peeler
- E72/011 Sink Skip - Stainless Steel - for MF10/MF10L/MF15/MF15L/VQ Peeler

The versatile, energy-efficient MF15 (1PH) is a multi-functional peeler which is ideal for medium to large kitchens, with a single-phase power supply. A variety of plate options means it can be used to wash and peel root vegetables, including potatoes and onions, wash mussels, clams and other bivalve shellfish, and spin salads.

With a thicker peeling plate for long operating life, the MF15 (1PH) is able to peel up to 398kg of vegetables per hour in 15kg batches making it a cost-effective and labour-saving solution.

Easy to operate, the unit comes with an integral stand and removable filter basket. It has an

#### PRODUCT FEATURES

- Able to peel up to 398kg of vegetables per hour - in 15kg batches.
- Versatile - can be used to peel and wash veg and mussels, and spin salad.
- Interlocking lid and door ensure safe operation.
- Perspex viewing pane allows you to monitor the peeling progress.
- Adjustable timer ensures accurate, repeatable peeling times.
- Modular construction facilitates easy maintenance.
- Thicker peeling plate delivers longer operating life.
- Suitable for medium to large kitchens with single-phase power supply.



IMC MF15 FREE-STANDING VEGETABLE PEELER - 1 PHASE - W 481  
MM - 0.37 KW

MODEL: F59/520

#### WEIGHTS & DIMENSIONS

Width	481 mil
Depth	635 mil
Height	1177 mil
Weight	51.5 kg

#### SHIPPING DETAILS

Ship Width	68 cm
Ship Depth	51 cm
Ship Height	125 cm
Ship Weight	56.65 kg
Number of Shipment Parcels	1
Ship Method	Small Parcel (FedEx, UPS, DHL)
Shipping Origin Zip Code	LN6 3QZ, UNITED KINGDOM
Quick Ship Product	No

#### PRODUCT CERTIFICATIONS



#### ENERGY SPECS

Primary Energy Type	Electric	Number of Electrical Plugs	Not Applicable
Electrical Total Amperage	3.6 A	Electrical Connection Type	Direct Hardwired
Electrical Volts	230V	Number of Electrical Conductor Wires	1
Electrical Total Wattage	370 W	Dedicated Circuit Required	Yes
Electrical Kilowatts	0.37 kW	Electrical Remarks	Single
Electrical Phase	1-Phase	Energy Saving	No
Electrical Plug Type	Hardwired		

#### ADDITIONAL SPECIFICATIONS

Airbreak	Yes
Control Type	On/Off, Rotary Control Knob
Hopper Load	10 kg
Motor Power	0.5 hp
Operator Safety Method	Interlock
Processing Capacity Per Hour	398 kg
Timer Type	Mechanical/Traditional Timer

IMC reserves the right to modify specifications or discontinue models without incurring obligation. Dimensions nominal.

Document Auto-Generated  
July 02, 2024





IMC MF15 FREE-STANDING VEGETABLE PEELER - 1 PHASE - W 481  
MM - 0.37 KW

MODEL: F59/520

**BIDDING SPECIFICATIONS**

Bidding Specifications Not Available.

**TECHNICAL DRAWING**

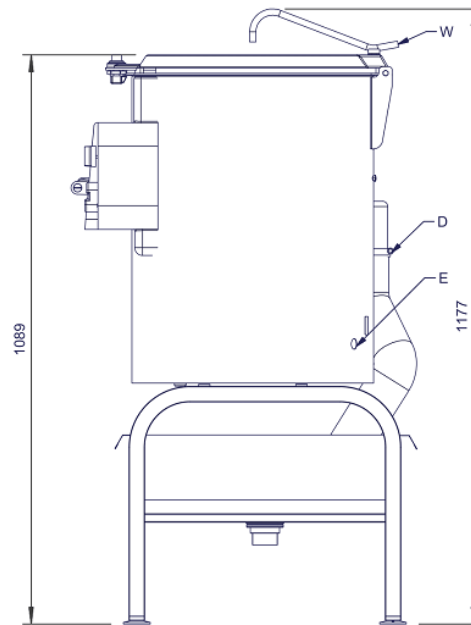
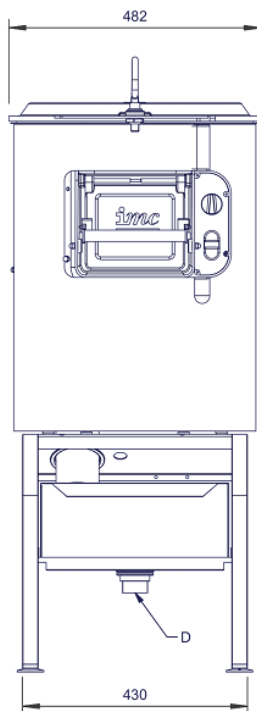
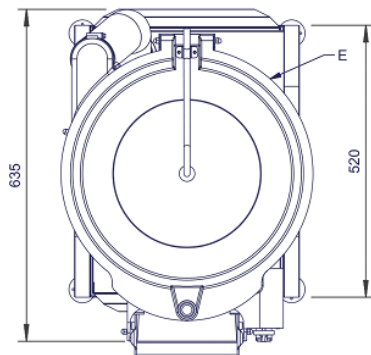

IMC reserves the right to modify specifications or discontinue models without incurring obligation. Dimensions nominal.

Document Auto-Generated  
July 02, 2024