



Fast and efficient, the 725 Waste Disposer enables medium-sized kitchens to remove waste quickly and simply. It is able to dispose of 400kg of food waste per hour and handles up to 850 covers per sitting, making it ideal for hotels, schools and hospitals.

The 725 Waste Disposer is suitable for medium waste - small pork and chicken bones, vegetables and fruit. Its compact design allows table mounting, making it quick and easy to load, saving staff time and labour.

With a smooth stainless steel finish, the 725 Waste Disposer is easy to clean, enabling kitchens to

PRODUCT FEATURES

- Fast and efficient disposal of up to 400kg of food waste per hour.
- Handles up to 850 covers per sitting - ideal for medium-size kitchens.
- For medium waste (plate waste, vegetables and peelings, meat and fish scraps).
- Compact design allows hopper to be table-mounted, for quick and easy loading.
- Manually reversible motor to extend operational life.
- Suitable for medium kitchens with single-phase power supply.



**IMC VULTURE 725 IN-TABLING FOOD WASTE DISPOSER - 1 PHASE
- W 338 MM - 1.1 KW**

MODEL: F60/100

WEIGHTS & DIMENSIONS

Width	340 mil
Depth	472 mil
Height	733 mil
Weight	39.5 kg

SHIPPING DETAILS

Ship Width	63 cm
Ship Depth	48 cm
Ship Height	104 cm
Ship Weight	43.45 kg
Number of Shipment Parcels	1
Ship Method	Small Parcel (FedEx, UPS, DHL)
Shipping Origin Zip Code	LN6 3QZ, UNITED KINGDOM
Quick Ship Product	No

PRODUCT CERTIFICATIONS



ENERGY SPECS

Primary Energy Type	Electric	Number of Electrical Plugs	Not Applicable
Electrical Total Amperage	7.4 A	Electrical Connection Type	Direct Hardwired
Electrical Volts	230V	Number of Electrical Conductor Wires	1
Electrical Total Wattage	1100 W	Dedicated Circuit Required	Yes
Electrical Kilowatts	1.1 kW	Electrical Remarks	Single
Electrical Phase	1-Phase	Energy Saving	No
Electrical Plug Type	Hardwired		

ADDITIONAL SPECIFICATIONS

Airbreak	No
Control Type	On/Off
Meal Waste Servings Processed Per Sitting	850
Motor Power	1.5 hp
Operator Safety Method	Interlock
Self-Cleaning Capable	No
Waste Processing Capacity Per Hour: Weight	400 kg
Waste Types Processed	Medium (small pork/chicken bones, vegetables and fruit)

IMC reserves the right to modify specifications or discontinue models without incurring obligation. Dimensions nominal.

Document Auto-Generated
July 02, 2024





IMC VULTURE 725 IN-TABLING FOOD WASTE DISPOSER - 1 PHASE
- W 338 MM - 1.1 KW

MODEL: F60/100

BIDDING SPECIFICATIONS

Bidding Specifications Not Available.

TECHNICAL DRAWING

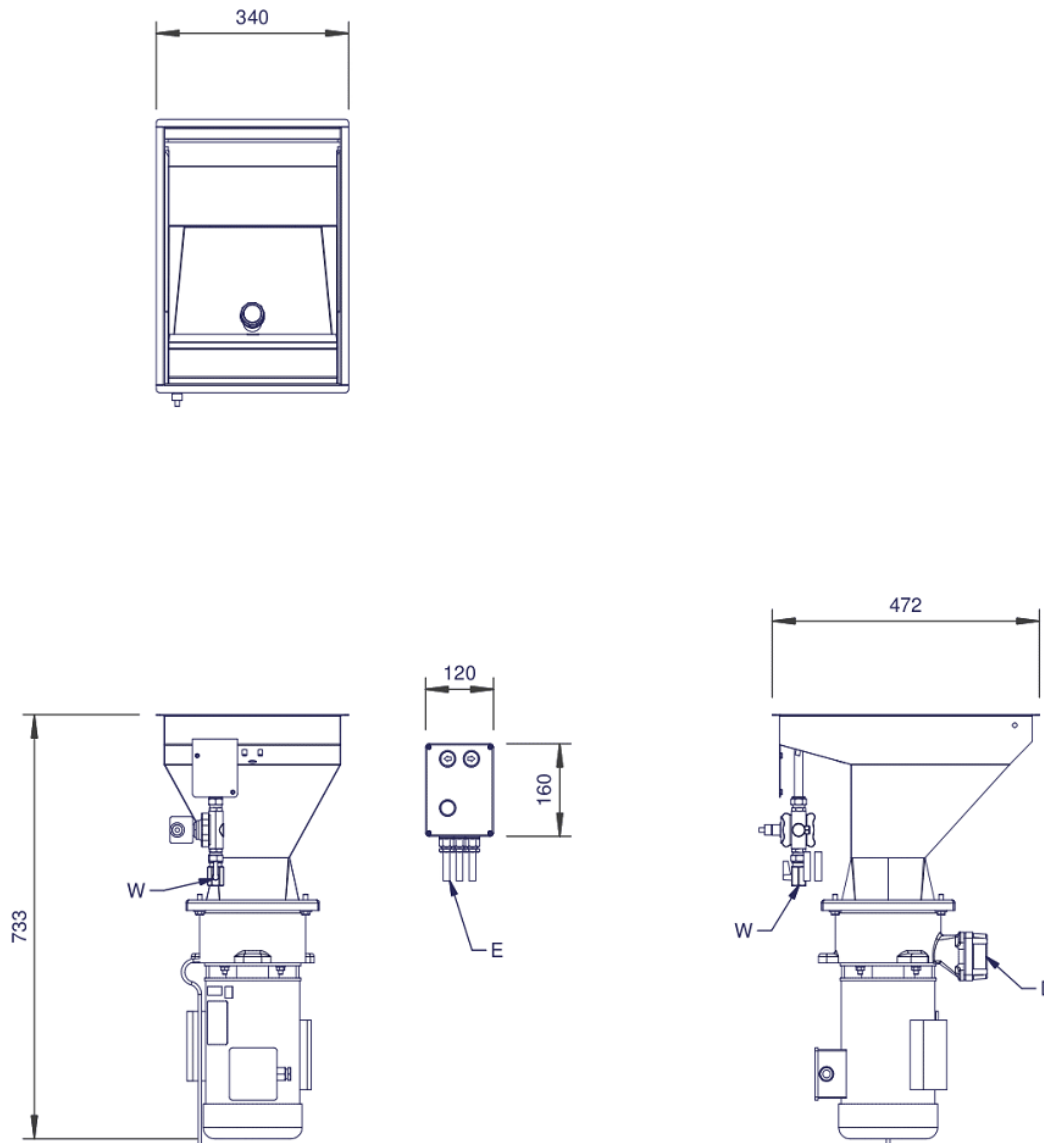

IMC reserves the right to modify specifications or discontinue models without incurring obligation. Dimensions nominal.

Document Auto-Generated
July 02, 2024