

Designed for locations where mains water supply is unavailable, the Mobile Hand Wash Station with accessories is an invaluable unit for organisations looking to increase hygiene and safety standards.

The station holds 10 litres of water per fill, enough for 85 hand washes. Easy to use, users simply fill the unit with water and plug it in. A foot-activated, infra-red operated tap dispenses water hygienically with no need for hand contact, with the temperature limited to 42°C for safety. An internal waste collection receptacle holds the dirty water, removing the need for a drainage system.

The sturdy, stainless steel unit is easy to wipe clean

PRODUCT OPTIONS AND ACCESSORIES

- S63/222 Bin Bag Holder for Mobile Hand Wash Station [inc. 20 x Bin Bags]
- S63/223 Bin Bags for Mobile Hand Wash Station [Pk 20] [fits S63/222 Holder]

PRODUCT FEATURES

- Provides hand washing facility in locations where mains water isn't available.
- Ideal for increasing hygienic hand washing facilities wherever required - just fill, plug in and go.
- Provides 85 hand washes - 10 litres per fill.
- Internal waste collection - no need for drainage.
- Water temperature limited to 42°C for user safety.
- Foot-activated, infrared-operated tap make unit hygienic, with no need for hand contact.
- Large wheels make hand wash station quick and easy to move.
- Constructed from sturdy and hygienic stainless steel, making it easy to wipe clean



WEIGHTS & DIMENSIONS

Width	450 mil
Depth	543 mil
Height	1136 mil
Weight	29 kg

SHIPPING DETAILS

Ship Width	68 cm
Ship Depth	57 cm
Ship Height	125 cm
Ship Weight	31.9 kg
Number of Shipment Parcels	1
Ship Method	Small Parcel (FedEx, UPS, DHL)
Shipping Origin Zip Code	LN6 3QZ, UNITED KINGDOM
Quick Ship Product	No

PRODUCT CERTIFICATIONS



ENERGY SPECS

Primary Energy Type	Electric	Number of Electrical Plugs	1
Electrical Total Amperage	12 A	Electrical Connection Type	Cord and Plug
Electrical Volts	230V	Number of Electrical Conductor Wires	1
Electrical Total Wattage	3000 W	Dedicated Circuit Required	No
Electrical Kilowatts	3 kW	Electrical Remarks	Single
Electrical Phase	1-Phase	Energy Saving	No
Electrical Plug Type	UK 3-Pin Plug		

ADDITIONAL SPECIFICATIONS

Sink Capacity	10 l
Sink Sill Height	950 mm
Water Faucet Actuation Method	Foot Activated Infrared Operated
Water Temperature Control	Factory Set

BIDDING SPECIFICATIONS

Bidding Specifications Not Available.





IMC IMCLEAN MOBILE HAND WASH STATION - W 450MM -
3.0KW

MODEL: F63/500

TECHNICAL DRAWING

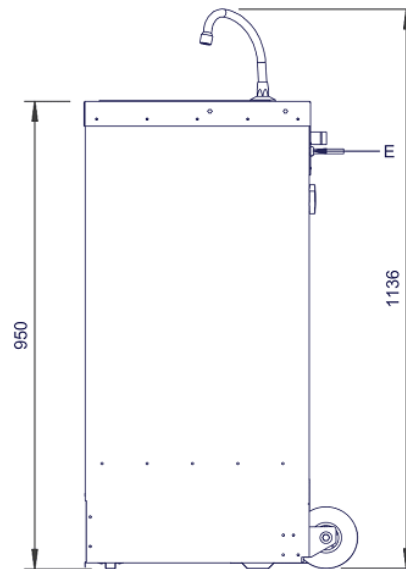
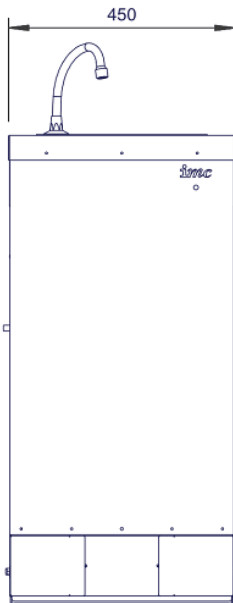
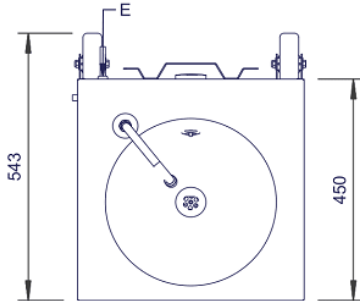

IMC reserves the right to modify specifications or discontinue models without incurring obligation. Dimensions nominal.

Document Auto-Generated
July 02, 2024