



IMC IMCLEAN JUNIOR REDUCED HEIGHT MOBILE HAND WASH STATION WITHOUT HEATER - INC. S/BACK, SOAP & PAPER TOWEL HOLDER - W 520MM

MODEL: F63/700



The junior mobile hand wash station helps provide additional reduced height hand washing facilities in schools. There is no restriction on where you can locate this hand wash station. The large 20 litre fresh water tank and foot operated water pump allows the provision of hygienic hand washing facilities where mains water and electric are not available. No install required, just fill and go!

AIA FILE NUMBER:

PRODUCT OPTIONS AND ACCESSORIES

- S63/222 Bin Bag Holder for Mobile Hand Wash Station [inc. 20 x Bin Bags]
- S63/223 Bin Bags for Mobile Hand Wash Station [Pk 20] [fits S63/222 Holder]

PRODUCT FEATURES

- Reduced 700 mm height - easy for children to reach the sink
- Provides hand washing facility in locations where mains water and electricity aren't available
- Ideal for increasing hygienic hand washing facilities wherever required - just fill and go!
- 20 litres per fill, dispenses up to 100ml per foot press, delivering 200 dispenses from one full tank
- Foot operated dispenser to also control the volume of water needed
- Tap dispenses via foot action, ensures hygienic operation, with no need for hand contact
- Internal waste collection - no need for drainage
- Large wheels make the hand wash station quick and easy to move
- Constructed from sturdy and hygienic stainless steel, including handy accessories, making it easy to wipe clean
- Supplied with splashback and space for soap dispenser and paper towels, for easy and convenient access to soap and towels
- Optional bin ring available providing a handily located bin for disposal of paper towels

ITEM NUMBER:



**IMC IMCLEAN JUNIOR REDUCED HEIGHT MOBILE HAND WASH
STATION WITHOUT HEATER - INC. S/BACK, SOAP & PAPER TOWEL**

MODEL: F63/700

WEIGHTS & DIMENSIONS

Width	520 mil
Depth	592 mil
Height	1003 mil
Weight	24 kg

SHIPPING DETAILS

Ship Width	57 cm
Ship Depth	67.5 cm
Ship Height	115 cm
Ship Weight	26.4 kg
Number of Shipment Parcels	1
Ship Method	Small Parcel (FedEx, UPS, DHL)
Shipping Origin Zip Code	LN6 3QZ, UNITED KINGDOM
Quick Ship Product	No

PRODUCT CERTIFICATIONS



ENERGY SPECS

Primary Energy Type	No Energy Utilities
---------------------	---------------------

ADDITIONAL SPECIFICATIONS

Sink Capacity	20 l
Sink Sill Height	700 mm
Water Faucet Actuation Method	Manual Foot Pump

BIDDING SPECIFICATIONS

Bidding Specifications Not Available.



IMC IMCLEAN JUNIOR REDUCED HEIGHT MOBILE HAND WASH
STATION WITHOUT HEATER - INC. S/BACK, SOAP & PAPER TOWEL

MODEL: F63/700

TECHNICAL DRAWING

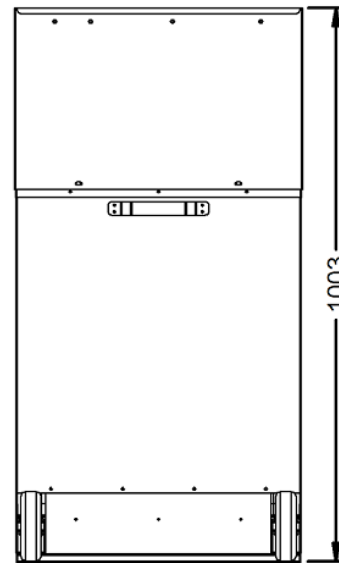
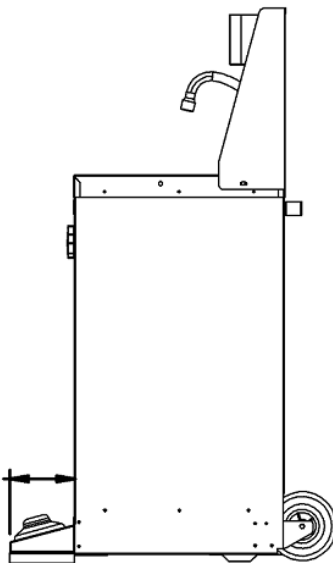
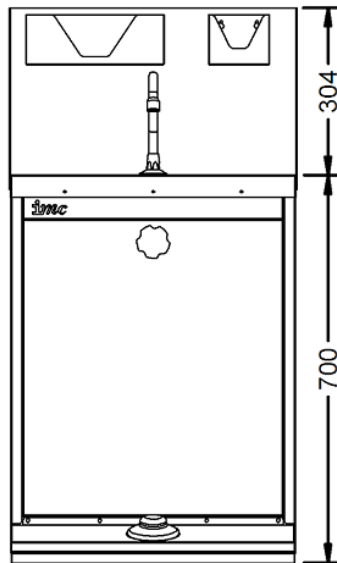
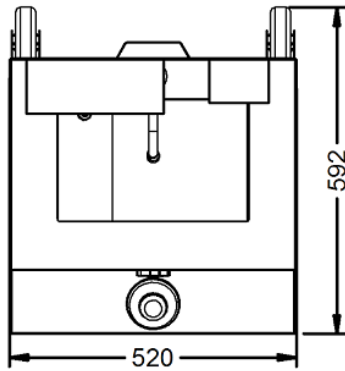

IMC reserves the right to modify specifications or discontinue models without incurring obligation. Dimensions nominal.

Document Auto-Generated
July 02, 2024

