



#### PRODUCT OPTIONS AND ACCESSORIES

- A29/003 Lid Retaining Strap for SP/VQ Potato Peeler
- S72/221 Pedestal for VQ Potato Peeler [H 750/800/850/900/950 mm - adjustable]
- E72/011 Sink Skip - Stainless Steel - for MF10/MF10L/MF15/MF15L/VQ Peeler
- S72/220 Trolley for VQ Potato Peeler [H 890 mm]
- S72/023 Waste Ejector for SP/VQ Potato Peeler [2" BSP]

With a small footprint and quiet running motor, the countertop VQ3.5 (1PH) peeler is ideal for smaller kitchens with a single-phase power supply. Despite its compact size, it has the power to peel up to 62.9kg of potatoes per hour, in 3.5kg batches, saving operators both space and time.

Simple and safe to operate, the VQ3.5 can be easily mounted on a sink unit to save worktop space. An optional height-adjustable pedestal can provide additional flexibility.

Constructed from rust-proof stainless steel, the VQ3.5 is robust and low maintenance, with a heavy-duty belt and pulley drive. Its corrosion-

#### PRODUCT FEATURES

- Able to peel 62.9kg of potatoes per hour, in 3.5kg batches
- Small footprint and quiet operation, ideal for smaller kitchens
- Compact design for countertops and sink drainers
- Heavy-duty belt and pulley for simple and safe operation
- Self-draining cylinder with smooth profile for easy cleaning
- Long-lasting, rust-proof cast aluminium plate for effective peeling
- Suitable for kitchens with single-phase power supply
- WRAS-compliant Class A air-break and brass spray nozzle to prevent water escape



**IMC VQ3.5 COUNTER-TOP POTATO PEELER - 1 PHASE - W 425 MM  
- 0.18 KW**

**MODEL: F72/200**

**WEIGHTS & DIMENSIONS**

Width	653 mil
Depth	367 mil
Height	425 mil
Weight	28 kg

**SHIPPING DETAILS**

Ship Width	72 cm
Ship Depth	42 cm
Ship Height	56 cm
Ship Weight	30.8 kg
Number of Shipment Parcels	1
Ship Method	Small Parcel (FedEx, UPS, DHL)
Shipping Origin Zip Code	LN6 3QZ, UNITED KINGDOM
Quick Ship Product	No

**PRODUCT CERTIFICATIONS**



**ENERGY SPECS**

Primary Energy Type	Electric	Number of Electrical Plugs	1
Electrical Total Amperage	1.2 A	Electrical Connection Type	Cord and Plug
Electrical Volts	230V	Number of Electrical Conductor Wires	1
Electrical Total Wattage	180 W	Dedicated Circuit Required	No
Electrical Kilowatts	0.18 kW	Electrical Remarks	Single
Electrical Phase	1-Phase	Energy Saving	No
Electrical Plug Type	UK 3-Pin Plug		

**ADDITIONAL SPECIFICATIONS**

Airbreak	Yes
Control Type	On/Off, Rotary Control Knob
Hopper Load	3.5 kg
Motor Power	0.24 hp
Operator Safety Method	Interlock
Processing Capacity Per Hour	62.9 kg
Timer Type	Mechanical/Traditional Timer

IMC reserves the right to modify specifications or discontinue models without incurring obligation. Dimensions nominal.

Document Auto-Generated  
July 02, 2024





IMC VQ3.5 COUNTER-TOP POTATO PEELER - 1 PHASE - W 425 MM  
- 0.18 KW

MODEL: F72/200

**BIDDING SPECIFICATIONS**

Bidding Specifications Not Available.

**TECHNICAL DRAWING**

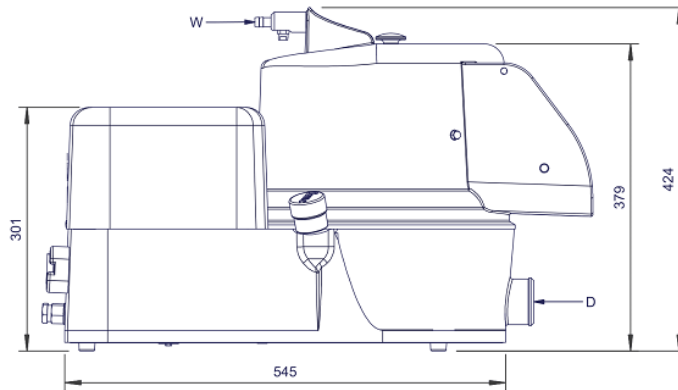
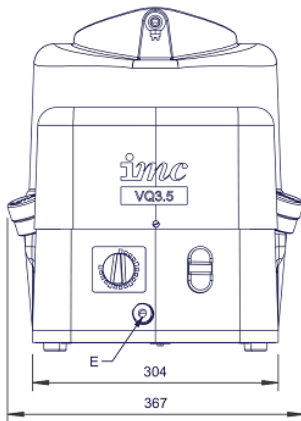
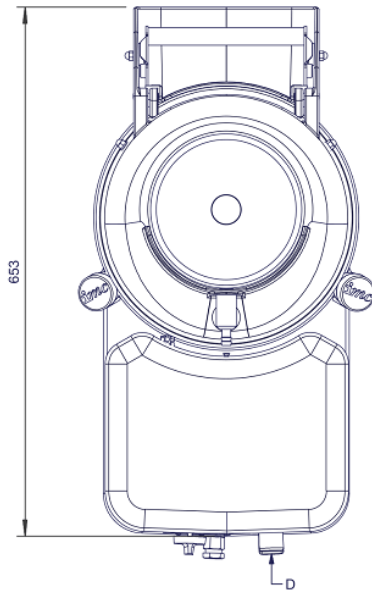

IMC reserves the right to modify specifications or discontinue models without incurring obligation. Dimensions nominal.

Document Auto-Generated  
July 02, 2024

