



#### PRODUCT OPTIONS AND ACCESSORIES

- A29/003 Lid Retaining Strap for SP/VQ Potato Peeler
- S72/221 Pedestal for VQ Potato Peeler [H 750/800/850/900/950 mm - adjustable]
- E72/011 Sink Skip - Stainless Steel - for MF10/MF10L/MF15/MF15L/VQ Peeler
- S72/220 Trolley for VQ Potato Peeler [H 890 mm]
- S72/023 Waste Ejector for SP/VQ Potato Peeler [2" BSP]

With a small footprint and quiet running motor, the countertop VQ7 (1PH) peeler is ideal for smaller kitchens with a single-phase power supply. Despite its compact size, it has the power to peel up to 90kg of potatoes per hour, in 7kg batches, saving operators both space and time.

Simple and safe to operate, the VQ7 can be easily mounted on a sink unit to save worktop space. An optional height-adjustable pedestal can provide additional flexibility.

Constructed from rust-proof stainless steel, the VQ7 is robust and low maintenance, with a heavy-duty belt and pulley drive. Its corrosion-resistant

#### PRODUCT FEATURES

- Able to peel 90kg of potatoes per hour, in 7kg batches
- Small footprint and quiet operation, ideal for smaller kitchens
- Compact design for countertops and sink drainers
- Heavy-duty belt and pulley for simple and safe operation
- Self-draining cylinder with smooth profile for easy cleaning
- Long-lasting, rust-proof cast aluminium plate for effective peeling
- Suitable for kitchens with single-phase power supply
- WRAS-compliant Class A air-break and brass spray nozzle to prevent water escape



# IMC VQ7 COUNTER-TOP POTATO PEELER - 1 PHASE - W 500 MM - 0.18 KW

## MODEL: F72/210

### WEIGHTS & DIMENSIONS

Width	653 mil
Depth	367 mil
Height	500 mil
Weight	29 kg

### SHIPPING DETAILS

Ship Width	71 cm
Ship Depth	41 cm
Ship Height	52 cm
Ship Weight	31.9 kg
Number of Shipment Parcels	1
Ship Method	Small Parcel (FedEx, UPS, DHL)
Shipping Origin Zip Code	LN6 3QZ, UNITED KINGDOM
Quick Ship Product	No

### PRODUCT CERTIFICATIONS



### ENERGY SPECS

Primary Energy Type	Electric	Electrical Plug Type	UK 3-Pin Plug
Electrical Total Amperage	1.2 A	Number of Electrical Plugs	1
Electrical Volts	230V	Electrical Connection Type	Cord and Plug
Electrical Total Wattage	180 W	Number of Electrical Conductor Wires	1
Electrical Kilowatts	0.18 kW	Electrical Remarks	Single
Electrical Phase	1-Phase	Energy Saving	No

### ADDITIONAL SPECIFICATIONS

Airbreak	Yes
Control Type	On/Off
Hopper Load	7 kg
Motor Power	0.24 hp
Operator Safety Method	Interlock
Processing Capacity Per Hour	90 kg
Timer Type	Mechanical/Traditional Timer

### BIDDING SPECIFICATIONS

Bidding Specifications Not Available.





IMC VQ7 COUNTER-TOP POTATO PEELER - 1 PHASE - W 500 MM -  
0.18 KW

MODEL: F72/210

TECHNICAL DRAWING

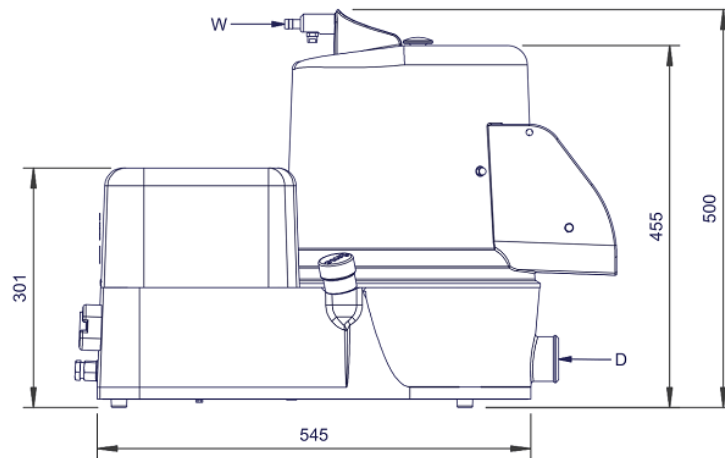
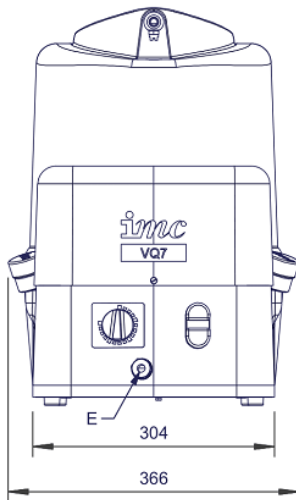
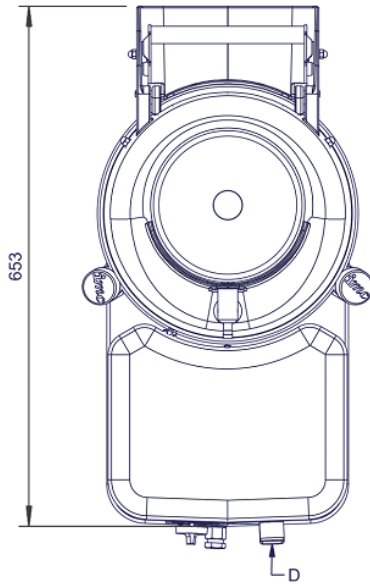

IMC reserves the right to modify specifications or discontinue models without incurring obligation. Dimensions nominal.

Document Auto-Generated  
July 02, 2024