



**04 SERIES FOOD WASTE DISPOSERS**  
**904 SERIES 28**  
**1204 / 1604 SERIES 17**  
**904 / 1204 / 1604 TROUGH UNITS- SERIES 10**

# Installation, Operating and Servicing Instructions



Please make a note of your product details for future use:

Date Purchased: \_\_\_\_\_

Model Number: \_\_\_\_\_

Serial Number: \_\_\_\_\_

Dealer: \_\_\_\_\_

\_\_\_\_\_

**A34/022 R12**

**ECN 4825 September 2021**

## CONTENTS

<b>MACHINE DIMENSIONS .....</b>	<b>4</b>
<b>INSTALLATION AND HEIGHT ADJUSTMENT .....</b>	<b>5</b>
<b>FITTING CONTROL BOX AND SAFETY BAFFLE.....</b>	<b>5</b>
<b>INTRODUCTION .....</b>	<b>6</b>
<b>DELIVERY .....</b>	<b>6</b>
<b>INSTALLATION.....</b>	<b>7</b>
<b>SELECTION OF SITE .....</b>	<b>7</b>
<b>SILVER SAVER (OPTIONAL EXTRA).....</b>	<b>7</b>
<b>ORDER OF CONNECTION FOR ALL INSTALLATION OPTIONS .....</b>	<b>7</b>
<b>INSTALLATION METHOD 1 – FREE STANDING MACHINES .....</b>	<b>8</b>
<b>INSTALLATION METHOD 2 – UNDER TABLING WITH HOPPER RIM ATTACHMENT .....</b>	<b>9</b>
<b>INSTALLATION METHOD 3 – UNDER TABLING WITH WELDED ATTACHMENT .....</b>	<b>11</b>
<b>ATTACHMENT OF CONTROL BOX.....</b>	<b>12</b>
<b>WASTE OUTLET CONNECTION.....</b>	<b>13</b>
<b>WATER SUPPLY CONNECTION .....</b>	<b>13</b>
<b>ELECTRICAL CONNECTION .....</b>	<b>14</b>
<b>FITTING OF REMOTE CONTROL BUTTON BOX .....</b>	<b>15</b>
<b>TESTING .....</b>	<b>15</b>
<b>OPERATION.....</b>	<b>15</b>
<b>INITIAL OPERATION .....</b>	<b>15</b>
<b>NORMAL OPERATION .....</b>	<b>16</b>
<b>RELEASING A JAM.....</b>	<b>16</b>
<b>WATER FLOW CONTROL (OPTIONAL EXTRA).....</b>	<b>16</b>
<b>MAINTENANCE .....</b>	<b>17</b>
<b>USAGE .....</b>	<b>17</b>
<b>WIRING DIAGRAM 904 – SINGLE PHASE .....</b>	<b>18</b>
<b>WIRING DIAGRAM 904/1204/1604 – THREE PHASE 4 WIRE .....</b>	<b>18</b>
<b>SEAL ASSEMBLY .....</b>	<b>20</b>
<b>Fig 9: Seal Assembly 904 .....</b>	<b>20</b>
<b>Fig 10: Seal Assembly 1204 / 1604 .....</b>	<b>20</b>
<b>MODEL 904 .....</b>	<b>21</b>

<b>PARTS ILLUSTRATION .....</b>	<b>21</b>
<b>PARTS LIST 904 .....</b>	<b>22</b>
<b>Parts List Model 904 Food Waste Disposer (continued) .....</b>	<b>23</b>
<b>MODELS 1204 &amp; 1604 .....</b>	<b>24</b>
<b>PARTS ILLUSTRATION .....</b>	<b>24</b>
<b>PARTS LIST .....</b>	<b>25</b>
<b>Model 1204 &amp; 1604 Food Waste Disposer.....</b>	<b>25</b>
<b>Parts List Model 1204 &amp; 1604 Food Waste Disposer (continued).....</b>	<b>26</b>
<b>TROUGH UNITS.....</b>	<b>26-33</b>
<b>FITTING OF MOTOR.....</b>	<b>26</b>
<b>ELECTRICAL CONNECTION.....</b>	<b>26</b>
<b>WATER AND WASTE CONNECTIONS.....</b>	<b>28</b>
<b>ON SITE ASSEMBLY DIAGRAM.....</b>	<b>29</b>
<b>WIRING DIAGRAM - SINGLE PHASE.....</b>	<b>30</b>
<b>WIRING DIAGRAM - THREE PHASE FOUR WIRE.....</b>	<b>31</b>
<b>WIRING DIAGRAM - THREE PHASE FIVE WIRE.....</b>	<b>32</b>
<b>GUARANTEE .....</b>	<b>33</b>
<b>SERVICE INFORMATION.....</b>	<b>34</b>

# MACHINE DIMENSIONS

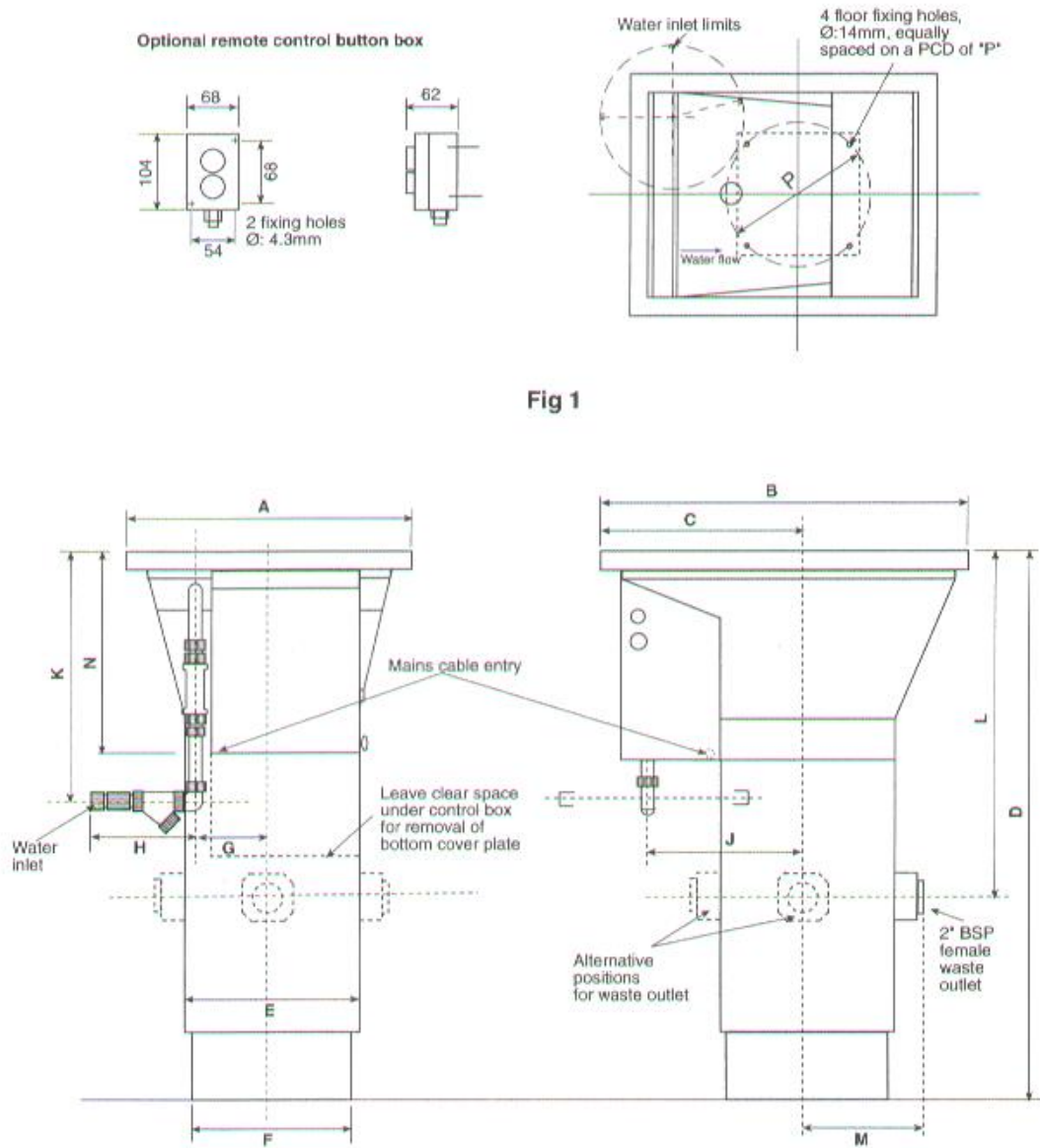

Model	A	B	C	DMIN	DMAX	E	F	G	H	J	K	L	M	N	P
904-3ph	438	564	321	790	905	275	252	110	105	252	396	508	178	295	298
904-1ph	438	564	321	800	905	275	252	110	105	252	396	508	178	295	298
1204	514	740	361	850	900	322	298	125	138	283	410	499	202	310	362
1604	514	740	361	850	900	322	298	125	138	283	410	499	202	310	362

## INSTALLATION AND HEIGHT ADJUSTMENT

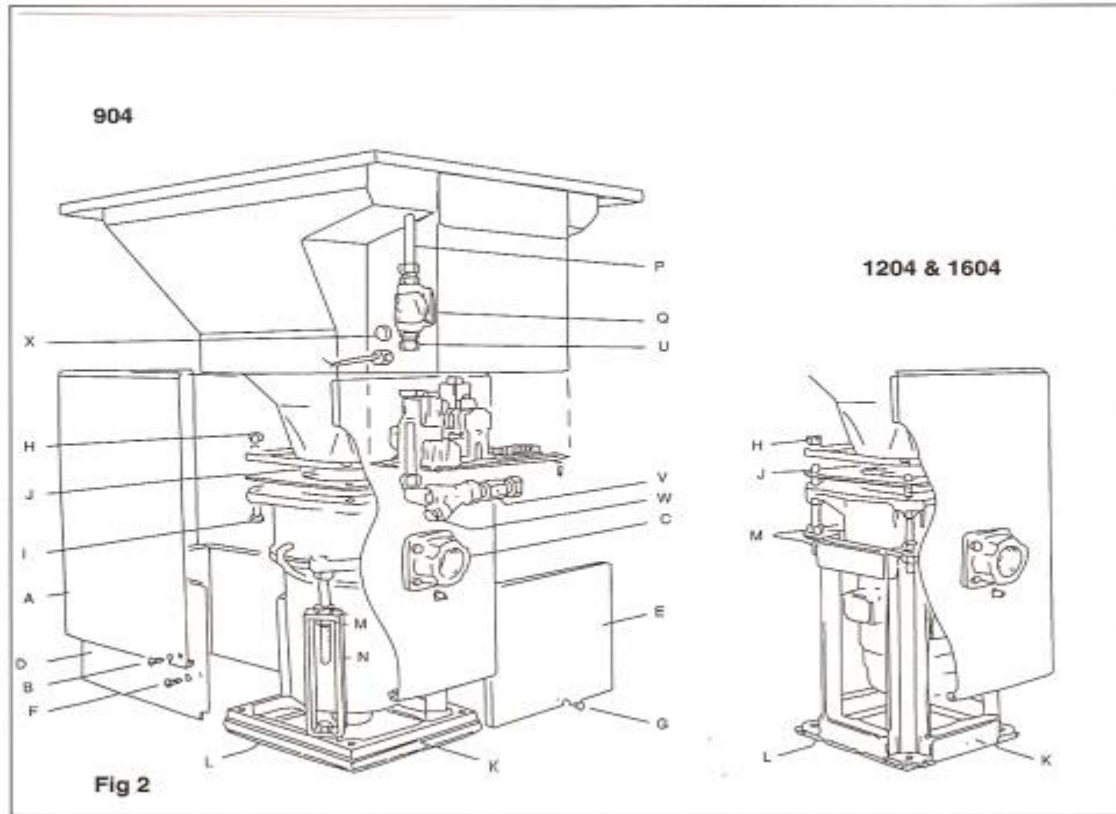

## FITTING CONTROL BOX AND SAFETY BAFFLE

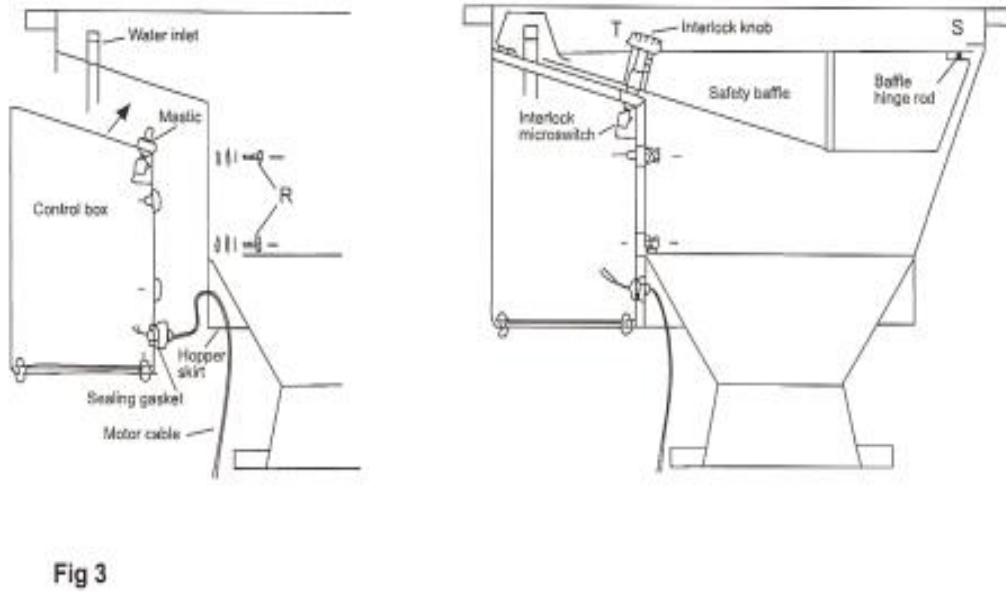

# INTRODUCTION

This machine is intended for the disposal of food waste matter by maceration under an automatic water flow and discharge into the drainage system. There are three versions: -

- 904 with motor size 1.5HP (1.1kW)
- 1204 with motor size 3.0HP (2.2kW)
- 1604 with motor size 5.5HP (4.0kW)

Please select your preferred installation method and read these instructions carefully for trouble-free installation and operation.

## **Please observe these instructions carefully**

This guarantee applies in this form to installations within the UK only.

# DELIVERY

Please notify the carrier and the supplier within 24 hours if anything is missing or damaged.

Check that the correct machine has been supplied and that the voltage, marked on the rating plate on the motor, is suitable for the supply and control voltage available.

### **EITHER -**

**Fully assembled 04 Food Waste Disposer with following items loose: -**

<b>Description</b>	<b>Quantity</b>
Release Key	1
Feeding Pusher	1
Rubber Floor Sealing Gasket	1
Instruction Handbook	1
Self-adhesive Operating Instruction Plaque	1
Hopper Rim (Optional)	1
Remote Control Button Box (Optional)	1

### **OR -**

**Basic unit 04 Food Waste Disposer for connection to hopper already supplied and welded into tabling: -**

<b>Description</b> (All the above items, plus)	<b>Quantity</b>
Baffle	1
Control Box	1
Tube of Sealant	1

**Please observe the following instructions carefully.**

# INSTALLATION

## **For the Installer:**

These Instructions contain important information designed to help the user obtain the maximum benefit from the investment in an IMC Food Waste Disposer. Please read them carefully before starting work, and consult with the supplier in the event of any queries.

Be sure to leave this Instruction Manual with the user after the installation of the machine is complete.

IMC 04 Food Waste Disposers may be installed in three ways: -

Method 1 - Free standing

Method 2 - Under tabling with Hopper Rim attachment

Method 3 - Under tabling with Welded attachment

All machines are operated from the built-in Control Box or, additionally, from a Remote Control Button Box which can be supplied as an optional extra.

## **SELECTION OF SITE**

Select the site of the 04 Food Waste Disposer with care so that it is convenient both for the major source of food waste and for access by machine operators.

The machines are designed to be installed with the control buttons on the left hand end of the unit and facing front. A space of at least 220mm must be left below the control box to give access for servicing purposes.

## **SILVER SAVER (OPTIONAL EXTRA)**

When waste disposers are installed next to dishwashing machines it is recommended that they be fitted with silver saver type safety baffles, which prevent the loss of cutlery into the units.

## **ORDER OF CONNECTION FOR ALL INSTALLATION OPTIONS**

Install in the following sequence:

- 1 Secure and seal the machine to the floor
- 2 Adjust height and level, and where appropriate, fit to tabling
- 3 Connect waste outlet to the drains
- 4 Connect water supply piping
- 5 If appropriate, connect Remote Control Button Box
- 6 Connect the electricity supply
- 7 Test and make any necessary adjustments
- 8 Fix self-adhesive Instruction Plaque in a prominent position adjacent to machine

## INSTALLATION METHOD 1 – FREE STANDING MACHINES

1. Remove the three-sided section of the upper cladding (A-Fig 2) by undoing the screws on either side (B). One part of the cladding remains attached at the waste outlet (C).
2. Remove the lower cladding which is in two parts (D and E) held together by two crews (F) and attached to the base casting or frame by screw (G).
3. Position the machine with the waste outlet (C) facing in the chosen direction. Allow space for the necessary trap.
4. If the hopper needs to be moved to a different position relative to the waste outlet, undo the four hopper retaining nuts (H). Lift the hopper and turn as required. Replace ensuring that the gasket (J) remains undisturbed. Replace nuts, or bolts and nuts (H) and tighten up uniformly all round. Do not over tighten but ensure that the gasket is nipped firmly and the hopper is rigidly fixed without distortion of its bottom flange.

**WARNING - IF THIS JOINT IS NOT CORRECTLY MADE, WATER LEAKAGE MAY OCCUR**

5. Clearly mark the floor through the floor fixing holes in the base casting or frame (K) or mark out the floor in accordance with the dimensions (Fig 4).

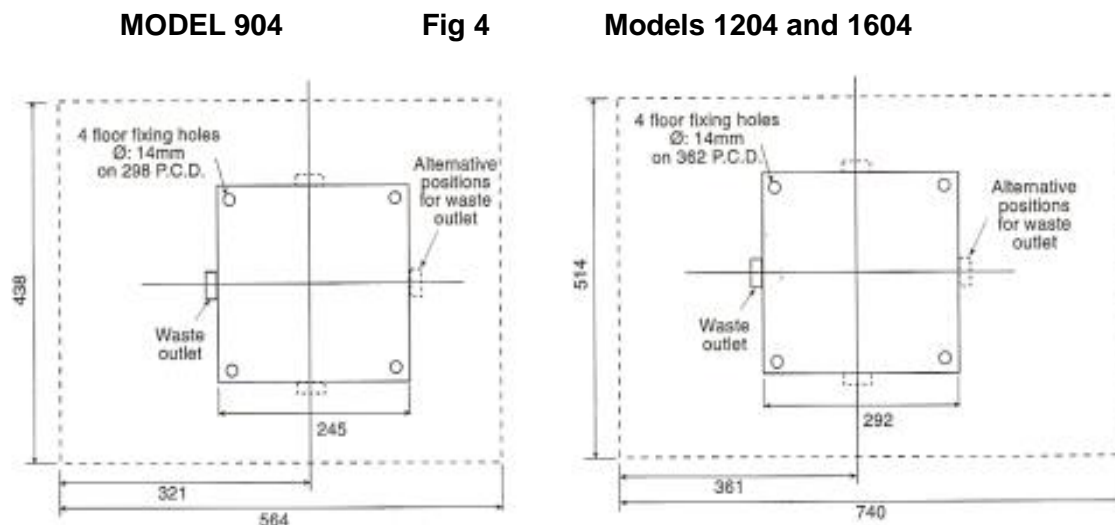

6. Drill the floor in the positions marked for the appropriate fixings. These may be rawbolts, coach screws, wood screws or whatever is most suitable for the particular floor surface and sub-structure. The base casting or frame will accept bolts up to 12mm diameter. Ensure that the fixings are of adequate size and that the floor surface is sound, level and flat.
7. Place the rubber floor-sealing gasket (L) in position over the four floor holes.
8. Position the machine on the rubber floor sealing gasket taking care that it is not damaged or displaced.



9. Insert and tighten the floor fixing bolts or screws.
10. Using a spirit level, check that the top of the hopper is level in both planes and that it is at the required height. To adjust height on the 904 models, slacken the nuts (M) at the top of the three height adjustment legs (N) and adjust as necessary. When correct, tighten all nuts (M) and re-check levels. On the 1204 and 1604 models, slacken the top nuts (M) and adjust as necessary. When correct, tighten all nuts and re-check levels.
11. Replace the motor cladding sections in the reverse order as described for removal in points 1 and 2.
12. Continue with SUPPLY CONNECTION INSTRUCTIONS.

## INSTALLATION METHOD 2 – UNDER TABLING WITH HOPPER RIM ATTACHMENT

1. A special rim is welded to the cutout in the tabling. The machine hopper is raised outside it to make an overlapping joint, which is then sealed with suitable mastic.
2. The hopper rim will normally have been welded in place by the fabricator, and the tabling should be installed and fixed in position prior to installing the IMC food waste disposer.
3. The necessary cutout in the tabletop is shown in Fig 5 and the hopper rim is depicted in Fig 7.
4. Remove the motor cladding as for Method 1, 1.
5. Remove the lower cladding as for Method 1, 2.
6. If necessary, lower the height of the machine until the top of the hopper will just pass below the bottom of the hopper rim. Allow about 5 mm clearance.

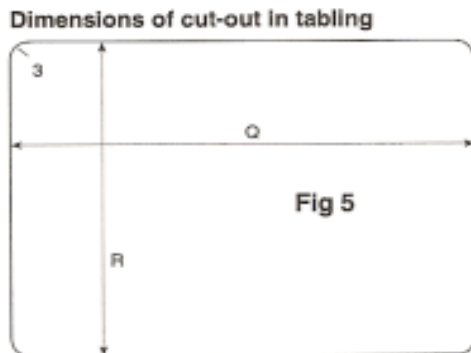

Dimensions	904	1204/1604
Q	506	684
R	380	456

All dimensions in mm

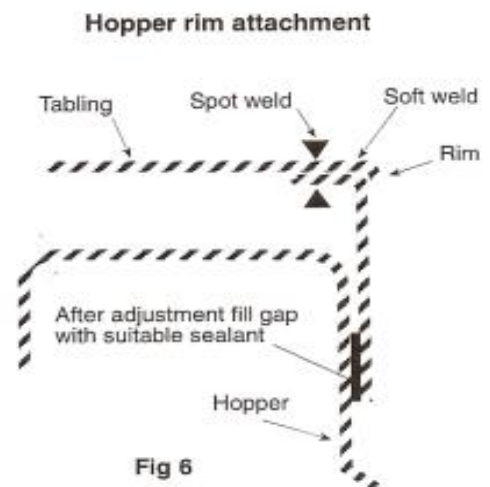

### Minimum height:

904 1ph: 790mm  
 904 3ph: 800mm  
 1204 and 1604: 850mm

7. Height is adjusted as for Method 1, 10.

8. Position the machine accurately below the hopper rim.
9. Clearly mark the floor through the floor fixing holes in the base casting or frame (K).
10. Drill the floor as for Method 1, 6.
11. If necessary, change the direction of the waste outlet (C) to suit the installation as for Method 1, 4.
12. Place the rubber floor-sealing gasket (L) in position over the four floor holes.
13. Position the machine below the hopper rim on the rubber floor-sealing gasket, taking care not to damage or displace the gasket.
14. Insert and tighten the floor fixing bolts or screws.
15. Raise the machine height until the hopper fits snugly around the welded rim (as shown at Fig 6). If possible adjust the height so that there is a full overlap, but ensure that there is a least 10mm overlap.
16. Seal the resulting joint (as shown at Fig 6) thoroughly and carefully with suitable mastic to achieve a complete and hygienic joint.
17. Replace the motor cladding as for Method 1, 11
18. Continue with SUPPLY CONNECTION INSTRUCTIONS.

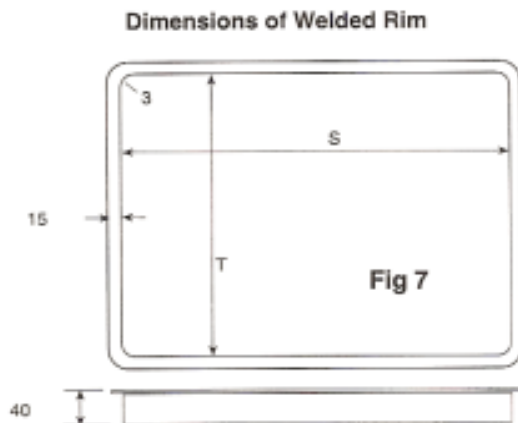

Dimensions	904	1204/1604
S	494	672
T	368	444

All dimensions in mm

## INSTALLATION METHOD 3 – UNDER TABLING WITH WELDED ATTACHMENT

The waste disposer hopper is welded directly to the cutout in the tabling. The fabricator of the tabling will normally undertake the necessary welding work, and a hopper will have been sent in advance to enable this to be done. Where this is not the case and a complete unit is to be welded into tabling, it is first necessary to separate the control box, the hopper and the motor unit. The procedure for this is the reverse of steps 10 to 16 below and in the section headed

The re-assembly and installation on site should be carried out only after the tabling is installed and fixed in position.

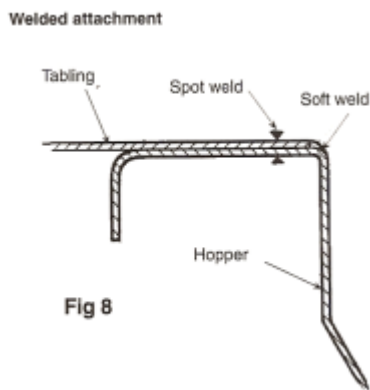

1 Remove the motor cladding as for Method 1, 1.

2 Remove the lower cladding as for Method 1, 2.

3 Adjust the height of the top of the motor unit in the same way as for Method 1, 10 until it is 3mm lower than the square flange at the bottom of the hopper.

**Minimum height of motor unit:** 904 3ph: 370mm, 904 1ph: 380mm, 1204 & 1604: 470mm over studs. Ensure that the top face of the motor unit is level and parallel with the hopper flange.

4 Position the motor unit under the hopper flange with the waste outlet (C) facing the required direction.

5 For 904, ensure accuracy of positioning by temporarily inserting the four bolts (I) from above the hopper flange. On the 1204/1604 the holes in the hopper flange must be centred on the studs below.

6 Prepare the floor fixing holes as for Method 1, 5-6.

7 Place the rubber floor-sealing gasket (L) in position over the four floor holes.

8 Position the motor unit below the hopper flange on the rubber floor-sealing gasket (L), taking care not to damage or displace the gasket.

9 Insert the floor fixing bolts or screws but do not tighten.

10 Carefully insert gasket (J) between the top face of the motor unit and the hopper flange. On the 1204 and 1604 machines the gasket has to be fitted over the hopper attachment studs. Ensure that tearing or crinkling does not damage it. It may be necessary to adjust the height further to accomplish this, particularly for 1204 or 1604 machines.

11 Raise the machine into contact with the hopper by means of the height adjustment nuts (M) ensuring that the top face of the motor unit remains level.

12 On 904 machines, insert the four bolts (I) from below the motor unit flange, fit spring washers and nuts (H) and tighten uniformly. On 1204/1604 machines the hopper-

fixing studs will have engaged during the raising of the machine. Fit washers and nuts (I) and tighten uniformly.

**WARNING - IF THIS JOINT IS NOT CORRECTLY MADE, WATER LEAKAGE MAY OCCUR**

13 Again using the height adjustment nuts (M), raise the machine evenly to produce a slight upward pressure on the tabling. Clamp rubber floor sealing gasket to the floor.

14 Tighten the lower height adjustment nut in each pair, holding the top one firmly.

15 Tighten the floor fixing bolts or screws.

16 Attach the control box in accordance with the instructions under that heading

**ATTACHMENT OF CONTROL BOX**

- i. Apply a 6mm ring of the supplied mastic sealant around the top face of the interlock shouldered boss (Y) (Fig 3), avoiding contact with the thread.
- ii. Ensure that the sealing gasket is in place on the motor cable outlet bush and pass the cable through the hopper skirt. Raise the control box into position, locating the cable bush and the interlock boss so that the latter protrudes through the hopper surface and the ring of mastic is compressed. At the same time, the water pipe (P-Fig 2) on the hopper should be engaged in the solenoid valve (Q).
- iii. Keeping the control box pressed upwards fit 4 screws (R) with fibre and flat washers from the inside of the hopper. Tighten the screws and the water pipe connector and check other union nuts.
- iv. Connect the motor supply cable following the appropriate wiring diagram. 904 machines have in-line interconnections with the motor cable: 1204 and 1604 machines should be connected direct to the motor terminal box. Ensure that the Earth cable is connected.
- v. Fit the safety baffle by locating it on the baffle hinge rod (S) and screw home the spring loaded interlock knob (T)

**NOTE** – Check that the safety baffle knob lines up properly with the interlock screw and engages freely.

- vi. Replace the motor cladding as for method 1,11
- vii. Continue with the SUPPLY CONNECTION INSTRUCTIONS

## WASTE OUTLET CONNECTION

The machines are fitted with a standard 2" BSP female threaded outlet. The size of these outlets must not be reduced, and the drainpipe should run in 54mm outside diameter pipe work as far as its junction with the main pipe or outside manhole connection. The length of run between the machine and the main junction must be kept to a minimum and the pipe run must have a fall of at least 1 in 7. A running trap should be fitted, although "P" or "S" type traps can be used. Do not use bottle traps. Changes of direction should be made by bends rather than elbows and cleaning eyes should be fitted where possible, in accordance with standard plumbing practice. Copper pipe and compression fittings should be used, but plastic tubing is acceptable to most drainage authorities.

IMC 04 Food Waste Disposers must have an independent waste pipe, which does not also serve sinks, dishwashers and similar equipment. It is imperative that the waste pipe from the Disposer bypasses any grease trap, which may be present. If this outlet is positioned below the control box, it is important to use fittings, which give at least the minimum 220mm clearance, required for service access.

## WATER SUPPLY CONNECTION

A 15 mm cold water supply is required on 904 machines, 22mm on 1204 and 1604 machines, and the connection should be made to the service valve (V-Fig 2) supplied with the machine. The head of water should not be less than 0.18 bar (1.8m). The direction of the water supply connection on the IMC 04 Food Waste Disposers may be altered between the two positions shown at Fig 9. Loosen the compression-fitting nut (U-Fig 2) and gently turn the elbow to the required position. If the water pipe is run below the control box, it is important to give at least the minimum 220mm clearance required for service access.

When fitted with the standard hopper these machines have approval from the Water Research Centre for connection to a water supply via a storage cistern to which no other fittings are to be connected.

An alternative hopper with water inlet is available: it provides a Class A air gap so that the machine can be connected directly to a mains water supply.

The rate of flow required for normal food waste is as follows:

- (1) ASSEMBLE WATER ASSEMBLY AND CLAMP NUT LOOSELY TOGETHER AND PLACE OVER WATER SUPPLY PIPE AS FAR AS IT WILL GO
- (2) TIGHTEN UP CLAMP NUT, WITH WATER ASSEMBLY RUNNING PARALLEL TO SIDE OF BAFFLE SLOT, AS SHOWN

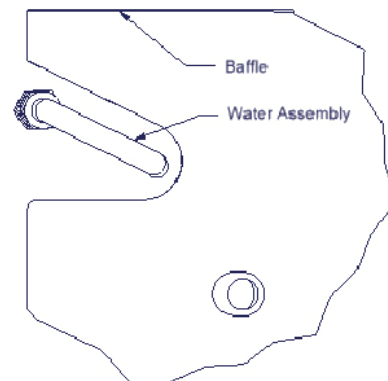
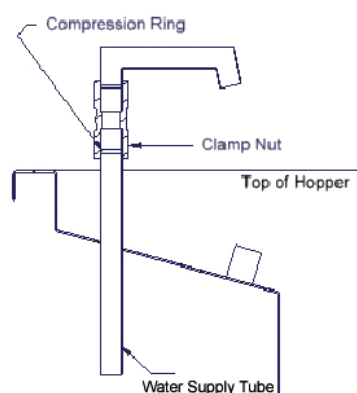

Model 904	14-18 litres per minute
Model 1204	18-27 litres per minute
Model 1604	27-36 litres per minute

Every machine is run and tested by IMC before dispatch. The water flow adjustments are made then but will require resetting when installed in the final location. The pipefittings supplied with the machine include a service valve (V) and this should be set fully open. Ensure that water supply demands made by other equipment served by the same supply pipe do not starve the Waste Disposer. To avoid this, run the piping in a size larger than recommended above and reduce at connection point to the machine.

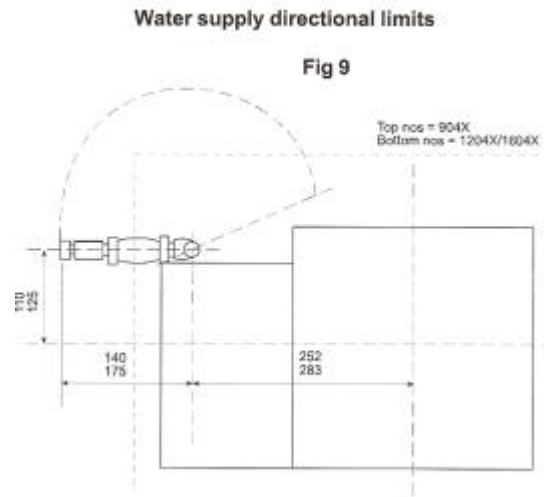

## ELECTRICAL CONNECTION

All electrical work must be carried out by a qualified electrician and in accordance with current local regulations.

Examine the rating plate attached to the machine to ensure that the characteristics shown are correct for the supply available. The rating plate is located on the control box.

It is recommended that the machine be connected to the electricity mains supply through a 30A isolator providing at least 3mm separation in all poles. The tabulation below illustrates typical fuse ratings for an ambient temperature of 25-35° centigrade. Should the environment temperature be greater than this, de-rate accordingly.

The mains lead fitted to the machine is the minimum required for individual connection to the mains supply. Site conditions may vary with additional length of cable run, encapsulation in trunking bunched with other cables etc. Should this apply, the electrician must alter the lead accordingly.

### **WARNING – THIS MACHINE MUST BE EARTHED**

If the supply cord becomes damaged it must be replaced by qualified electrician in order to avoid a hazard.

#### **Machine Ratings and Cable Coding**

<b>Machine Ratings</b>				
Model	Electricity Supply Volts-Phase-Hz	Output kW	Input kW	Fuse Rating Amps
904	230-1-50	1.1	1.45	16
	220-1-60			
	254-1-60			
904	400-3-50	1.1	1.45	6
	440-3-60			
1204	400-3-50	2.2	2.7	16
	440-3-60			
	380-3-60			
1604	400-3-60	4	4.82	16
	440-3-60			
	230-3-60			
	220-3-50			

<b>Mains cable coding</b>			
	3 phase 5 wire	3 phase 4 wire	1 phase
L1	Black	Blue	Brown
L2	Black	Black	
L3	Brown	Brown	
N	Blue		Blue
Earth	Green/Yellow	Green/Yellow	Green/Yellow

The supply to the machine must also be protected by a 30mA RCD.

## **FITTING OF REMOTE CONTROL BUTTON BOX**

In installations where the standard positioning of the control box is inconvenient or inaccessible, a remote unit may be installed at some other location by connecting into the control box. The remote button box may also be used as a repeater providing control from two locations.

1. Fit the remote button box in the required position i.e. on the wall, in tabling apron, etc.
2. Connect cable into the control box terminal block as wiring diagram, removing the blanking plug (X-Fig 2) and replacing it with cable gland supplied.

If your IMC 04 Food Waste Disposer was initially ordered with a remote control button box, this unit will be supplied pre-wired to the control box.

## **TESTING**

Check finally that all supply connections are correctly made and soundly fixed, that nothing has been left in the grinding chamber, that the rotor is free to rotate (use the release wrench if necessary) and that the interlock knob is screwed down.

The machine is now ready to operate.

# **OPERATION**

## **INITIAL OPERATION**

1. Switch on the electricity supply
2. Press the green button on the control box. The machine will run and the water will flow.
3. Inspect the waste piping for leaks. Estimate that the volume of water flowing is correct for the particular model – refer to WATER SUPPLY CONNECTION. If adjustments are needed, use a screwdriver to adjust the position of the slot on the control screw of the service valve (V – Fig 2). Maximum flow is with the slot in line with the pipe.
4. Try a small amount of food waste to check disposal and that no internal obstruction in the waste pipe will cause a blockage.
5. With the machine running unscrew the interlock knob (T – Fig 3). The machine will switch itself off almost immediately. By the time the knob is fully unscrewed and the safety baffle open, the rotor in the grinding chamber will have completely stopped.

When these checks, tests and adjustments are completed, the 04 IMC Food Waste Disposer is ready for use.

## **NORMAL OPERATION**

1. Ensure that the safety baffle is closed and the interlock knob is screwed down fully.
2. Press the green button to start. This also switches on the water flow
3. Feed waste into the hopper at a uniform rate, using the feeding pusher if necessary.
4. If the machine is overloaded, it will stop and a yellow lamp on the electronic control box will light. Switch on again to restart, as this will automatically cause the machine to reverse its direction of rotation.
5. If the machine stalls it will stop and the yellow lamp will light as for an overload, but this will be accompanied by a high pitched buzzer. Raise the safety baffle to stop the buzzer and release the jam as detailed in RELEASING A JAM.
6. If the main rotor seal is damaged and water passes through it, this will be detected by a sensor in the grinding chamber housing. The machine will cut out, the red lamp will light and the buzzer will sound. Raising the safety baffle can stop the buzzer, but the machine cannot be restarted until a Service Engineer has been called to replace the damaged seal and the sensor. This will prevent costly damage to the motor itself.
7. The machine is designed to shut off automatically after approximately 35 seconds when no waste is being processed so as to conserve water and power.
8. It can be restarted at any time and will continue to run until the sensors detect another extended period of idling or one of the fault conditions described above.

## **RELEASING A JAM**

As a result of a jam occurring the machine will stall and stop. Switch off the machine at the mains, unscrew the interlock knob and lift the safety baffle. Engage the prongs of the release key into the vanes of the rotor. Exert pressure in either direction to free the blockage and remove the offending item by hand. Check that the rotor is free to rotate through 360° and withdraw the release key. Close the safety baffle and screw down the knob fully.

## **WATER FLOW CONTROL (OPTIONAL EXTRA)**

Your IMC Food Waste Disposer is equipped with a device with which the operator can adjust the volume of water that flows through the Food Waste Disposer whilst it is processing food waste.

To reduce water flow, simply turn the water control knob to the left i.e. anti-clockwise. To increase water flow, turn the knob to the right i.e. clockwise.

When operating the FWD, the water flow control should initially be set at its highest position before turning it down whilst the waste is being processed. The rate of water flow can be adjusted up or down for each installation to take account of unique factors such as the length of, and number of bends in, the drainage piping, the fall of the pipe, the amount



of liquid already present in the waste and whether a Dewaterer and / or Grease Trap is fitted downstream of the FWD.

When operating the system on reduced water flow it is recommended that, at the end of each "session," the water flow is turned up full for a minimum of 15 seconds to ensure that any residue is flushed through the drainage system. A bucket of warm, soapy water poured into the FWD's hopper at the end of each day will both clean the equipment and help disperse any residual solids in the piping.

Note: The control knob operates within an arc from vertical (min water flow) to the 3 o'clock position (max water flow). Please do **NOT** force the control knob beyond its end stop positions.

Unless the FWD is being used to process food that is either consistently very wet or very dry, IMC recommends that the water pressure should be set at the mid-point of the published scale when the equipment is first installed.

## MAINTENANCE

**Daily:** Clean down thoroughly after use especially inside the hopper. Unscrew the safety interlock knob and open the baffle to gain access internally

Cleaning is assisted by the use of a low-pressure spray, an IMC Pre-Rinse Spray or a Reel-Kleen retractable hose reel.

Wipe over the exterior of the machine, including the back areas not normally visible. Proprietary cleaners may safely be used but avoid particularly aggressive cleaners and neat bleach solutions.

**6 monthly:** Clean water supply filter (W – Fig 2)

**12 monthly:** Check for motor bearing wear by:

- Sound of motor
- Side movement of rotor

**WARNING – BEFORE ATEMPTING SERVICE WORK ENSURE THAT ELECTRICITY SUPPLY AND WATER SUPPLY ARE TURNED OFF AT THE MAIN SUPPLY AND WATER STOPCOCK.**

## USAGE

1 The IMC 04 Food Waste Disposer is designed for the disposal of food waste. Fat can safely be disposed off provided it has solidified.



**2 DO NOT PUT STRING, CLOTH, PLASTIC, WIRE, GLASS, CORK OR METAL OBJECTS INTO THE MACHINE.**

3 Always start the machine before putting waste into it. Introducing mixed waste rather than accumulating and introducing waste of a similar nature into the machine will obtain more efficient disposal.

4 For environmental reasons, the grinding of inorganic materials should be avoided.

# WIRING DIAGRAM 904 – SINGLE PHASE

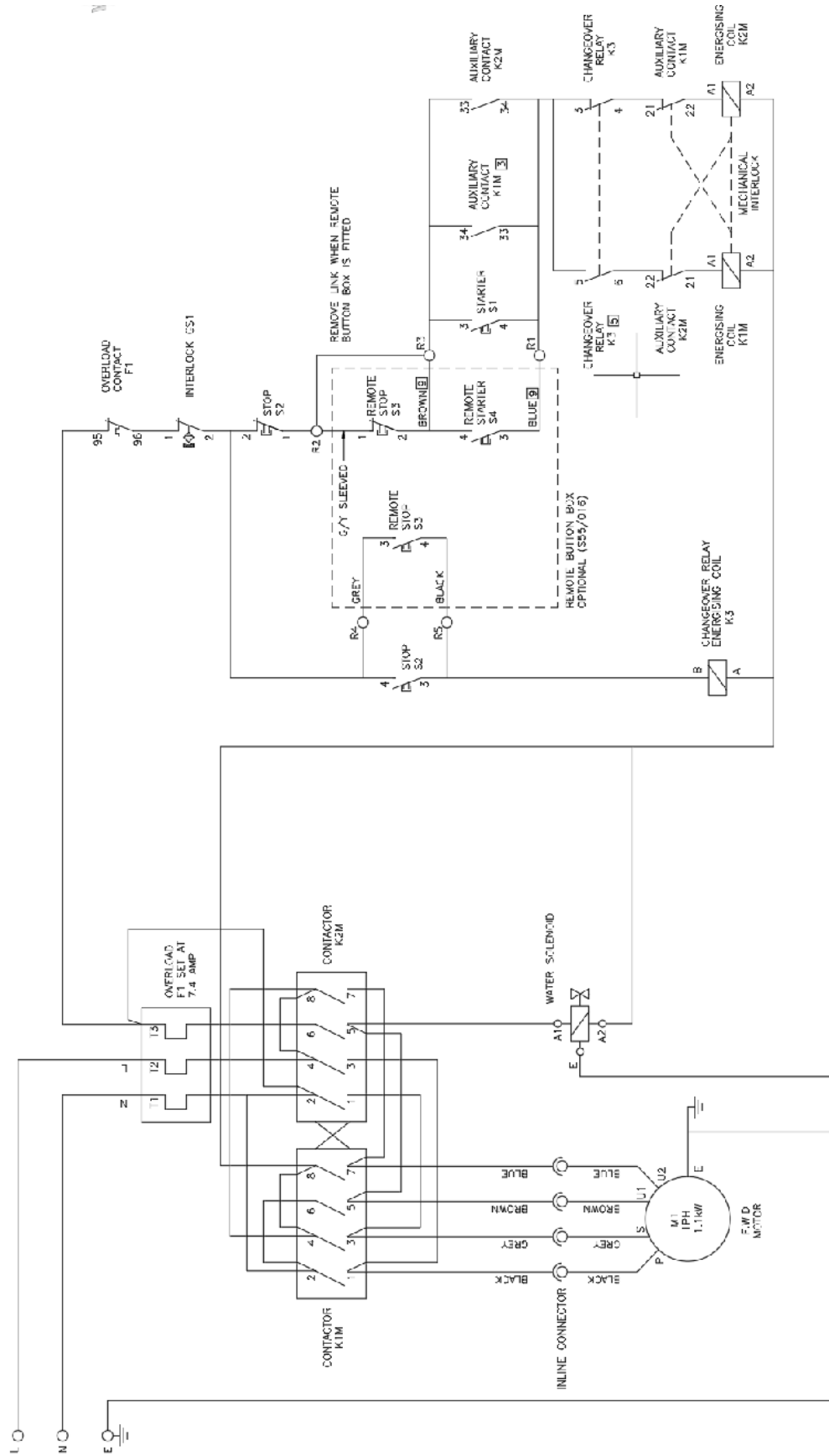

# WIRING DIAGRAM – 904 / 1204 / 1604 THREE PHASE

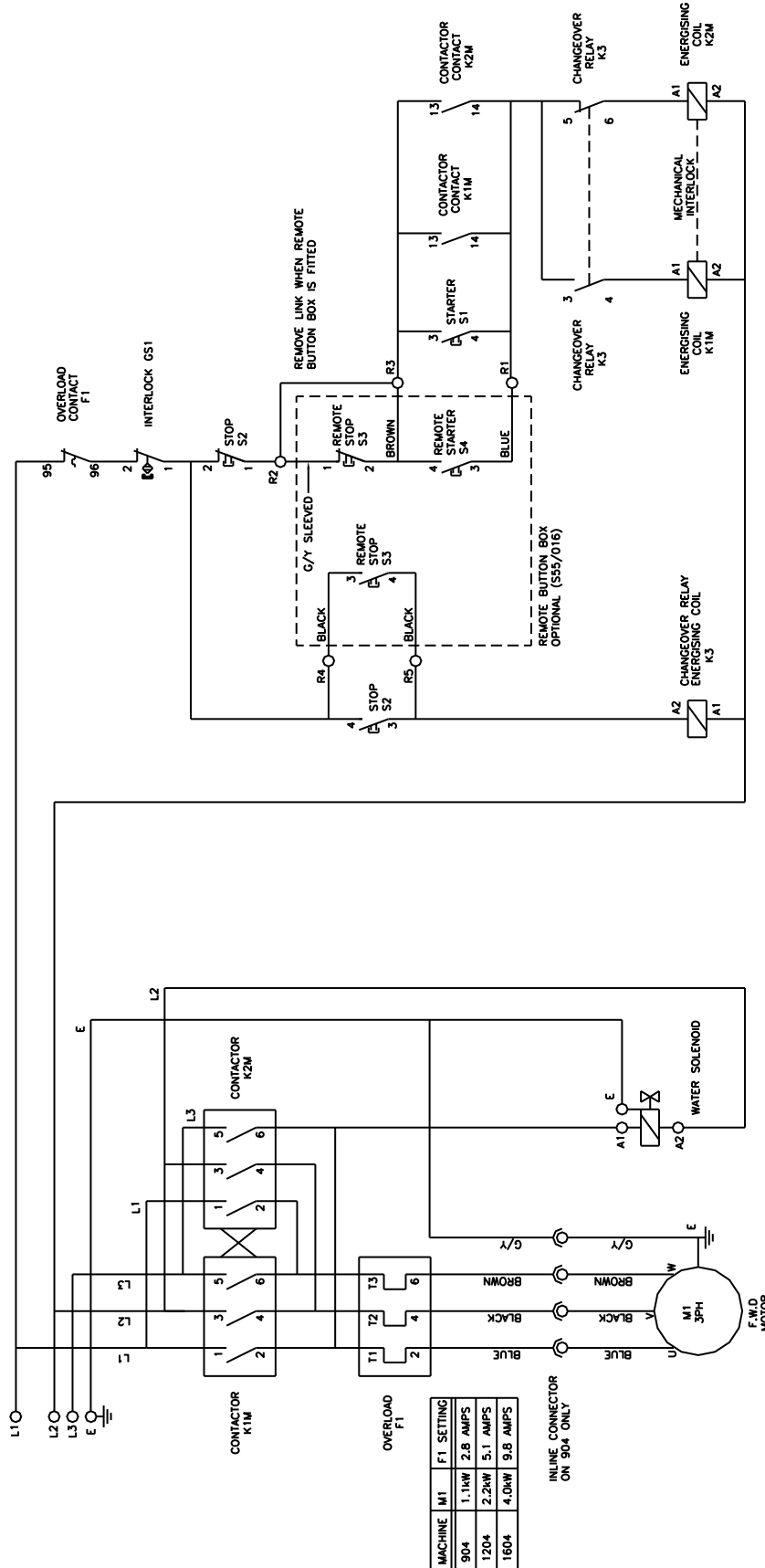

**SEAL ASSEMBLY**  
**Fig 9: Seal Assembly 904**

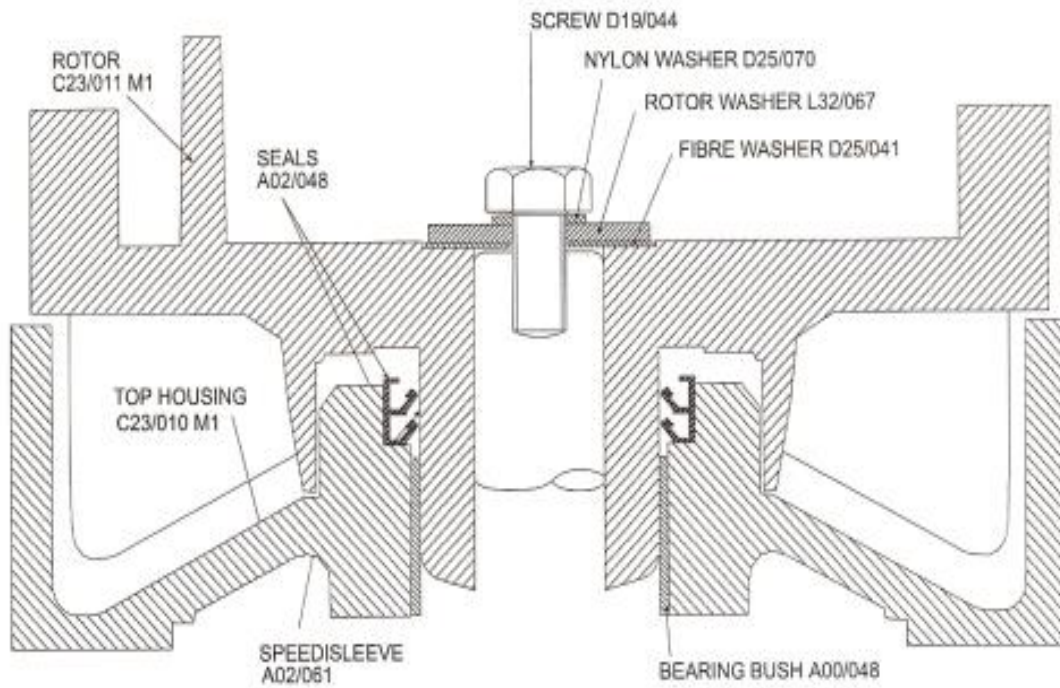

**Fig 10: Seal Assembly 1204 / 1604**

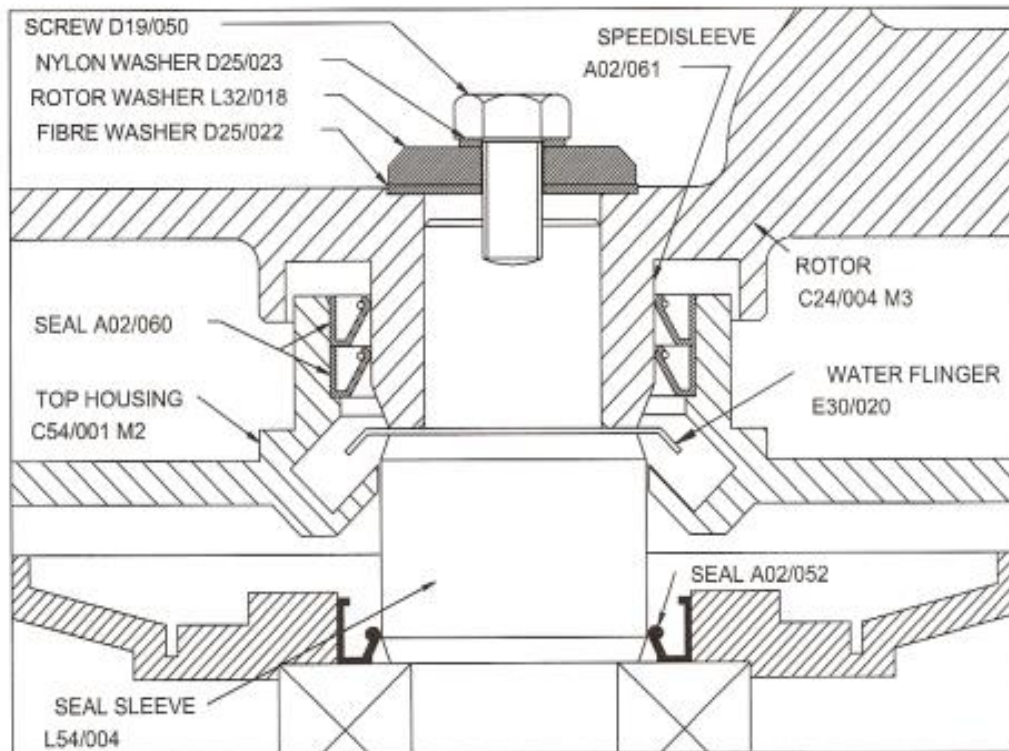

# MODEL 904 PARTS ILLUSTRATION

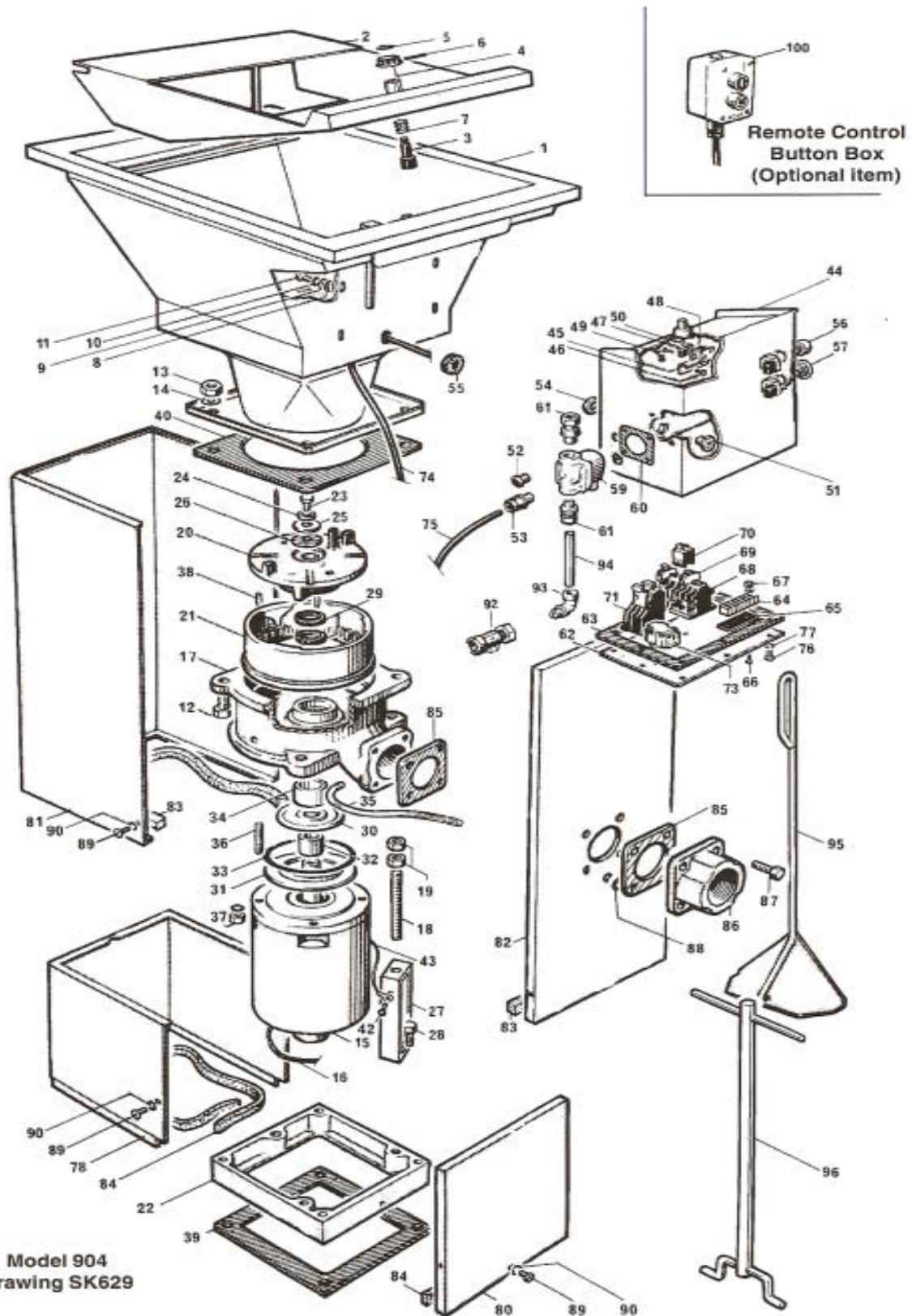

Model 904  
Drawing SK629

## PARTS LIST

### Model 904 Food Waste Disposer

To be read in conjunction with Drawing No SK629

REF	PART NO	DESCRIPTION	REF	PART NO	DESCRIPTION
1	E54/009	Hopper	42	D19/111	Screw M4 x 16mm Hex SS
2	E54/010	Baffle		D25/014	Washer M4 Normal SS
3	M81A	Interlock body Assembly		D25/033	Washer M4 Shakeproof SS
4	M69	Interlock Knob	43	S54/040	Cable Assy Earth
5	M48	Plug	44	E54/008Z1	Control Box
6	D26/017	Spirol Pin 3 x 35mm	45	E54/012	Micro-switch Bracket 1PH
7	A12/011	Compression Spring		E54/057	Micro-switch Bracket 3PH
8	D25/018	Washer Fibre 6 x 25 x 1.5mm		E54/058	Interlock Bracket 3PH
9	D25/038	Washer 6 x 25 x 1.0mm	46	D19/120	Screw M4 x 8mm Hex SS
10	D25/064	Washer 2BA Seloc		D25/014	Washer M4 Normal SS
11	D19/031	Screw M5 x 10mm Hex SS		D25/033	Washer M4 Shakeproof SS
12	D19/091	Screw M10 x 30mm Hex	47	G45/044	Micro-switch - 1PH
13	D20/039	Nut M10 Philidas ZPS		E32/073	Stop Bracket- 1PH
14	D25/010	Washer M10 Plain ZPS		G45/087	Micro-switch- 3PH
15	G40/069	Motor 1.1kW 220/240-1-50			
	G40/221	Motor 1.1kW 380/420-3-50	48	G308	Paxolin Insulator
	D27/015	Key	49	D21/034	Screw M3 x 16mm Pan SS
16	S54/018	Cable Motor to Couplers 1PH		D25/006	Washer M3 Shakeproof SS
	S54/030	Cable Motor to Couplers 3PH	50	L54/003	Interlock Slug
17	C23/010M1	Top Housing	51	A10/280	Cable Gland M20
18	D23/024	Stud M16 x 180mm ZPS	52	A10/425	Plug M20
19	D20/030	Nut M16 Half ZPS	53	A10/280	Cable Gland M20
20	C23/011M1	Rotor	54	A10/224	Gland Locknut M20 (52&53)
	A02/047	Speedi Sleeve	55	A11/178	Conduit Gasket
21	C13/005M1	Cutter	56	G45/015	Pushbutton – Green
22	C23/005M1	Base Ring		G45/016	Body Contact Assy N.O.
23	D19/044	Screw M8 x 16mm Hex SS	57	G45/033	Pushbutton – Red
24	D25/070	Washer Nylon M8		G230B	Body Contact Assy
25	L32/067	Washer 8 x 37 x 3mm SS	58		
26	D25/041	Washer Fibre 8 x 38 x 1.0mm	59	S54/063	Solenoid Valve ½” BSP – 1PH
27	E30/113	Adjusting Leg		S54/064	Solenoid Valve ½” BSP – 3PH
28	D19/109	Screw M16 x 25mm Hex	60	A11/166	Solenoid Gasket
	D08/049	Washer Plain 5/8”	61	J04/073	Straight Coupler 15mm ½” BSP
29	A02/048	Seal Single Lip 35x47x7mm	62	E54/011	Control Box Cover
30	E30/102	Rotor Flinger	63	A11/215	Control Box Gasket
31	E30/103	Flinger Baffle	64	G264	8 Way Terminal Block
32	L32/085	1PH Rotor Spacer (34mm)	65	L32/080	Insulator
32	L32/088	3PH Rotor Spacer (13mm)	66	D21/035	Screw M3 x 20mm Pan SS
33	A11/162	Motor Shield Gasket	67	D20/010	Nut M3 Full SS
34	A00/048	Bearing 35 x 39 x 20mm		D25/006	Washer M3 Shakeproof
35	J60/028	Nylon Tube 4 ID x 6 OD	68	G30/307	Contact – 1PH
36	D23/023	Stud M8 x 30mm		G30/303	Contact – 3PH
	D25/012	Washer M8 Seloc	69	G30/297	Aux. Contact N/O 1PH only
37	D20/023	Nut M8 Full ZPS	70		
38	L54/001	Dowel Pin 6 x 24mm	71	G30/305	Overload Relay 240V 1PH
39	A11/148	Base Gasket		G30/298	Overload Relay 415V 3PH
40	A11/145	Hopper Gasket			

## Parts List Model 904 Food Waste Disposer (continued)

To be read in conjunction with Drawing No SK629

REF	PART NO	DESCRIPTION
73	G30/163	Changeover Relay 240V 1PH
	G30/164	Changeover Relay 415V 3PH
	G254	Din Rail Clip
74	S54/090	Cable Assy C/Box to Couplers 1PH
	S54/030	Cable Assy C/Box to Couplers 3PH
75	S54/080	Cable Assy Mains Input 1PH
	S54/010	Cable Assy Mains Input 3PH
76	D21/101	Screw M4 x 10mm Pan Pozi SS
77	D25/035	Washer M4 Spring SS
78	E30/007	Base Casing
80	E30/008	Base Cover
81	E30/126	Motor Case
82	E30/127	Motor Cover
83	K04/060	Self Ad Foam Tape 12 x 15mm
84	K08/043	Self Ad Foam Tape 3 x 15mm
85	A11/098	Waste Outlet Gasket
86	C23/004M1Z	Waste Outlet
87	D19/097	Screw M6 x 30mm Hex ZPS
88	D25/005	Washer M6 Shakeproof SS
89	D21/101	Screw M4 x 10mm Pan Pozi SS
90	D25/035	Washer M4 Spring
92	J03/134	Ball Valve
93	J04/130	Elbow 15mm
94	J01/080	Copper Pipe
95	E09/111Z	Rammer
96	E30/035Z	Release Key
100	S55/016	Remote Control Button Box (Optional)

# MODELS 1204 & 1604 PARTS ILLUSTRATION

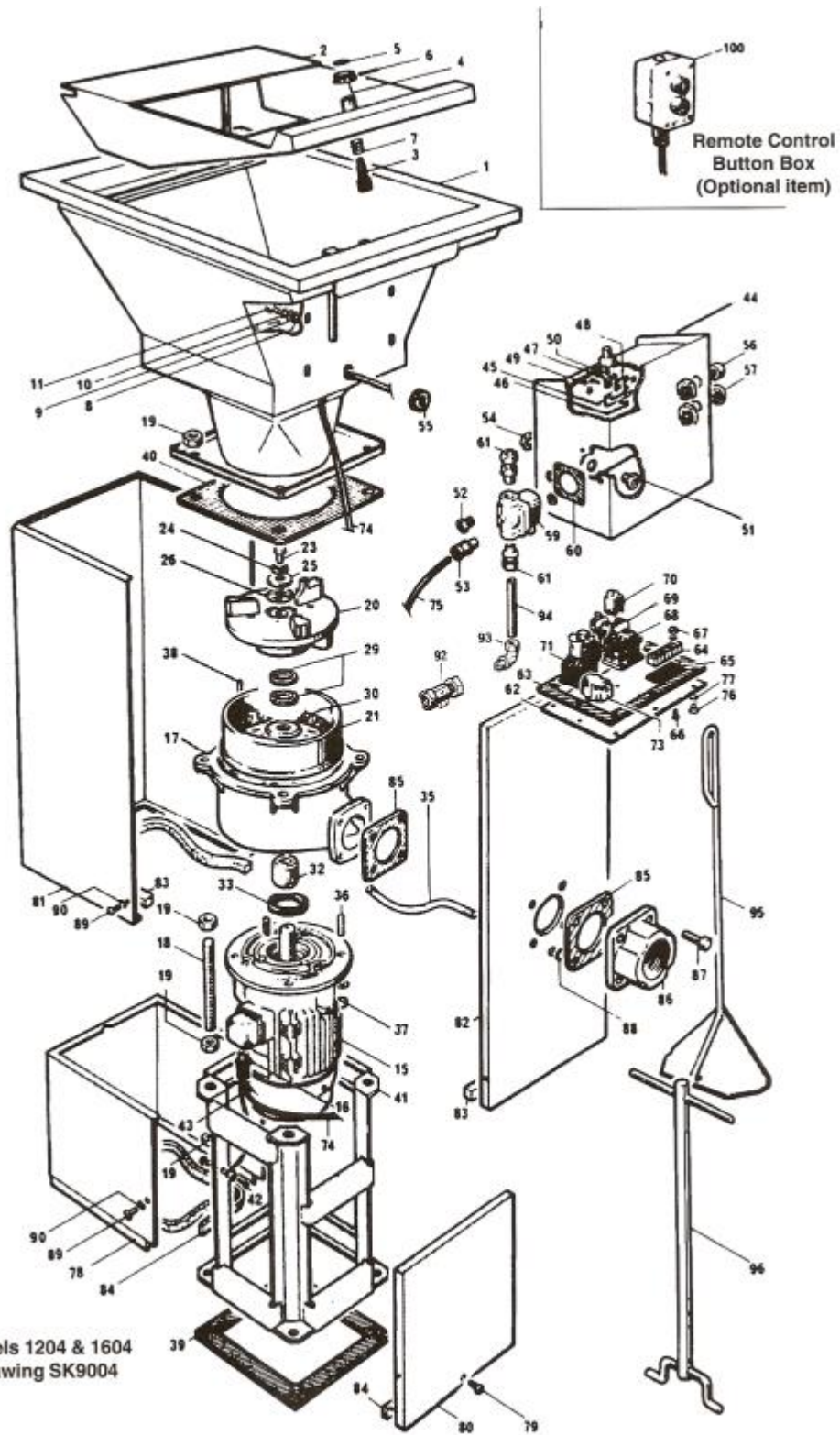



## PARTS LIST

### Model 1204 & 1604 Food Waste Disposer

To be read in conjunction with Drawing No SK9004

REF	PART NO	DESCRIPTION	REF	PART NO	DESCRIPTION
1	E54/018	Hopper		D20/011	Nut M4 Full SS
2	E54/017	Baffle	43	S54/336	Cable Assy Earth
3	M81A	Interlock body Assembly	44	E54/015Z1	Control Box
4	M69	Interlock Knob	45	E54/055	Interlock Switch Bracket
5	M48	Plug	46	D19/120	Screw M4 x 8mm Hex SS
6	D26/017	Spirol Pin 3 x 35mm		D25/014	Washer M4 Normal SS
7	A12/011	Compression Spring		D25/033	Washer M4 Shakeproof SS
8	D25/018	Washer Fibre 6 x 25 x 1.5mm	47	G45/087	Micro-switch
9	D25/038	Washer 6 x 25 x 1.0mm		E54/056	Stop Bracket
10	D25/064	Washer 2BA Seloc	48	G86/002	Insulator
11	D19/031	Screw M5 x 10mm Hex SS	49	D21/034	Screw M3 x 16mm Pan SS
12				D25/006	Washer M3 Shakeproof SS
13			50	L54/003	Interlock Slug
14			51	A10/280	Cable Gland M20
15	G40/122	Motor 2.2kW 415-3-50 (1204)	52	A10/425	Plug M20
	G40/123	Motor 4.0kW 415-3-50 (1604)	53	A10/280	Cable Gland M20
16	A10/266	Cable Gland M20	54	A10/224	Gland Locknut M20 (52&53)
	A10/274	Adaptor (1604 only)	55	A11/178	Conduit Gasket
17	C54/001M2	Housing	56	G45/015	Pushbutton Green
18	D23/024	Stud M16 x 180mm ZPS		G45/016	Body Contact Assy N.O.
19	D20/030	Nut M16 Half ZPS	57	G45/033	Pushbutton – Red
20	C24/004M2	Rotor		G230B	Body Contact Assy N.C.
21	C15/013M1	Cutter Ring	59	S54/062	Solenoid Valve 3/4" BSP
22					400V – 4 wire
23	D19/050	Screw M10 x 20mm Hex SS	60	A11/167	Solenoid Gasket
24	D25/023	Washer Nylon M10	61	J04/097	Straight Coupler 22mm 3/4" BSP
25	L32/018	Washer 10.5 x 42 x 6mm	62	E54/014	Control Box Cover
26	D25/022	Washer Fibre 10.5x43x1.0mm	63	A11/216	Control Box Gasket
27			64	G264	8 Way Terminal Block
28			65	L32/080	Insulator
29	A02/060	Seal	66	D21/035	Screw M3 x 20mm Pan SS
	A02/061	Speedi Sleeve	67	D20/010	Nut M3 Full SS
30	E30/020	Rotor Flinger		D25/006	Washer M3 Shakeproof
31			68	G30/303	Contacto – 400V – 1204 only
32	L54/004Z	Seal Sleeve		G30/378	Contacto – 400V – 1604 only
33	A02/052	Seal-Single Lip 45 x 60 x 8mm	69		
34			70		
35	J06/028	Nylon Tube 4 ID x 6 OD	71	G30/463	Overload Relay 5.7-7.6A 1204 only
36	D23/035	Stud M12 x 40mm ZPS		G30/305	Overload Relay 6A 1604 only
	D25/011	Washer M12 Normal ZPS	73	G30/164	Changeover Relay 415V 3PH
37	D20/033	Nut M12 Full Nyloc ZPS		G254	Din Rail Clip
38	D26/007	Tension Pin	74	S54/335	Cable Assy – C/box to Motor
	D22/046	Screw M10x16mm Soc Set Blk	75	S54/050	Cable Assy – Mains 3PH
39	A11/149	Base Gasket	76	D21/101	Screw M4 x 10mm Pan Pozi SS
40	A11/150	Hopper Gasket	77	D25/035	Washer M4 Spring SS
41	E54/013 Z	Motor Stand	78	E30/030	Base Casting
42	D21/101	Screw M4 x 10mm Pan Pozi	79	D22/022	Screw No8 x 1/2" Self Tap ZPS
	D25/014	Washer M4 Normal SS	80	E30/031	Base Cover
	D25/033	Washer M4 Shakeproof SS	81	E30/134	Motor Case

## Parts List Model 1204 & 1604 Food Waste Disposer (continued)

To be read in conjunction with Drawing No SK9004

REF	PART NO	DESCRIPTION
82	E54/025	Motor Casing Cover
83	K04/060	Self Ad Foam Tape 12 x 15mm
84	K08/043	Self Ad Foam Tape 3 x 15mm
85	A11/098	Waste Outlet Gasket
86	C23/004M1Z	Waste Outlet
87	D19/097	Screw M6 x 30mm Hex ZPS
88	D25/005	Washer M6 Shakeproof SS
89	D21/101	Screw M4 x 10mm Pan Pozi SS
90	D25/035	Washer M4 Spring SS
92	J03/135	Ballofix Valve
93	J04/277	Elbow 22mm
94	J01/081	Copper Pipe
95	E09/111Z	Rammer
96	E13/016BZ	Release Key
100	S55/016	Remote Control Button Box (Optional)

### TROUGH UNITS PAGES 27 TO 33

#### FITTING OF MOTOR

##### MOTOR UNIT FITTING

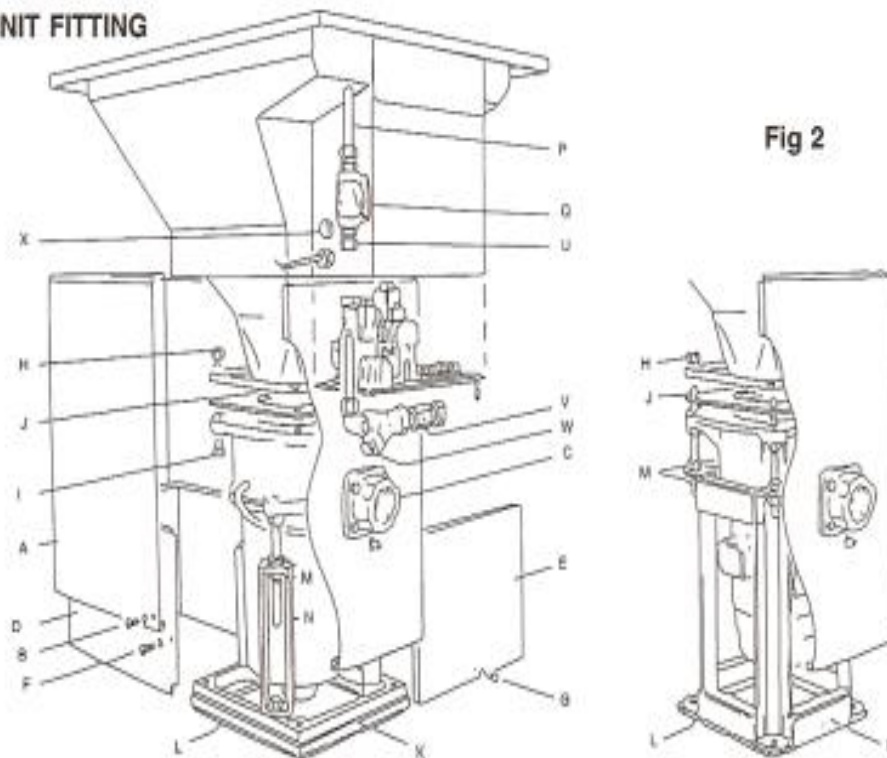

Follow these instructions once the trough hopper has been fitted to the tabling.

- 1 Removal of cladding from motor/rotor/cutter basic unit: Remove the three-sided section of the upper cladding (A-Fig 2) by undoing the screws on either side (B). One part of the cladding remains attached at the waste outlet (C). Remove the lower cladding which is in two parts (D and E) held together by two screws (F) and attached to the base casting or frame by screw (G).
- 2 Proceed to fit motor unit to underside of hopper temporarily, by jacking up until accurately located with hopper flange.
- 3 Clearly mark the floor through the floor fixing holes in the base casting or frame (K) or mark out the floor in accordance with Fig 4.
- 4 Position the machine with the waste outlet (C) facing in the chosen direction. Allow space for the necessary trap.
- 5 If the hopper needs to be moved to a different position relative to the waste outlet, undo the four hopper retaining nuts (H). Lift the hopper and turn as required. Replace ensuring that the gasket (J) remains undisturbed. Replace nuts, or bolts and nuts (H) and tighten up uniformly all round. Do not over-tighten but ensure that the gasket is nipped firmly and the hopper is rigidly fixed without distortion of its bottom flange.

**WARNING – IF THE JOINT IS NOT CORRECTLY MADE, WATER LEAKAGE MAY OCCUR**

- 6 Drill the floor in the positions marked for the appropriate fixings. These may be rawbolts, coach screws, wood screws or whatever is most suitable for the particular floor surface and sub-structure. The base casting or frame will accept bolts up to 12mm diameter. Ensure that fixings are of adequate size and that the floor surface is sound, level and flat.
- 7 Place the rubber floor-sealing gasket provided (L) in position over the four floor holes.
- 8 Position the motor unit on the rubber floor sealing gasket taking care that it is not damaged or displaced.
- 9 Insert and tighten the floor fixing bolts or screws.
- 10 Position hopper flange gasket on motor unit; carefully jack up motor unit level, to meet through hopper. Using a spirit level, check that the top of the hopper is level in both planes and that it is at the required height. To adjust height on the 904 models, slacken the nuts (M) at the top of the three height adjustment legs (N) and adjust as necessary. When correct, tighten all nuts (M) and re-check levels. On the 1204 and 1604 models, slacken the top nuts (M) and adjust as necessary. When correct, tighten all nuts and check levels.

## **ELECTRICAL CONNECTION**

All electrical work carried out must be carried out by a qualified electrician and in accordance with current local regulations. The trough unit electrics are supplied pre-assembled and interlinked via the interlock box cover (Fig Ta). The wiring diagrams shown on the following pages (Fig Tb, Tc and Td) illustrate the electrical system.

Proceed to connect electrics as follows:

- 1 Fit water spray pipe into trough hopper; assemble all threads with PTFE tape or a pipe sealant suitable for use with plastic pipe. Once fitted loosely, ensure to tighten water spray pipe into water solenoid valve elbow first. Position spray holes approximately 45° to top of trough. Tighten back nut and rubber gasket towards elbow.
- 2 Tighten blanking cap on other end of spray pipe and repeat with back nut and rubber gasket.

**NOTE: Care must be taken not to over-tighten plastic fittings.**

- 3 This spray pipe assembly supports water solenoid valve and flexible electrics conduit.
- 4 Proceed to connect up motor. Remove backnut from flexible electrics conduit, feed all leads and conduit end trough side of hopper, tighten back nut inside hopper. Connect motor leads to flying leads from motor; connect earth lead to motor support chassis with screw, lock washer and nut provided.
- 5 Refit all motor cladding.
- 6 Proceed to connect interlock micro-switch to interlock box cover terminal strip (see Fig Tb). Connect two flying leads from micro-switch to blue and brown from remote control box. Ensure earth lead (green/yellow) fitted to interlock box cover is connected to earth stud inside trough interlock box.
- 7 Ensure interlock box cover gasket is in position, tighten the six screws to retain the cover.
- 8 Select suitable position on wall for remote control box, mark wall and drill four holes to receive appropriate fixings. Position box, tighten fixing screws.
- 9 Connect mains input cable from remote control box to mains supply through suitable protection e.g. fused isolator or circuit breaker (not included). Select fuse in accordance with rating table on page.

## **WATER AND WASTE CONNECTIONS / ADJUSTING AND TESTING**

Please refer to previous similar paragraphs on pages 14 and 16

# ON-SITE ASSEMBLY

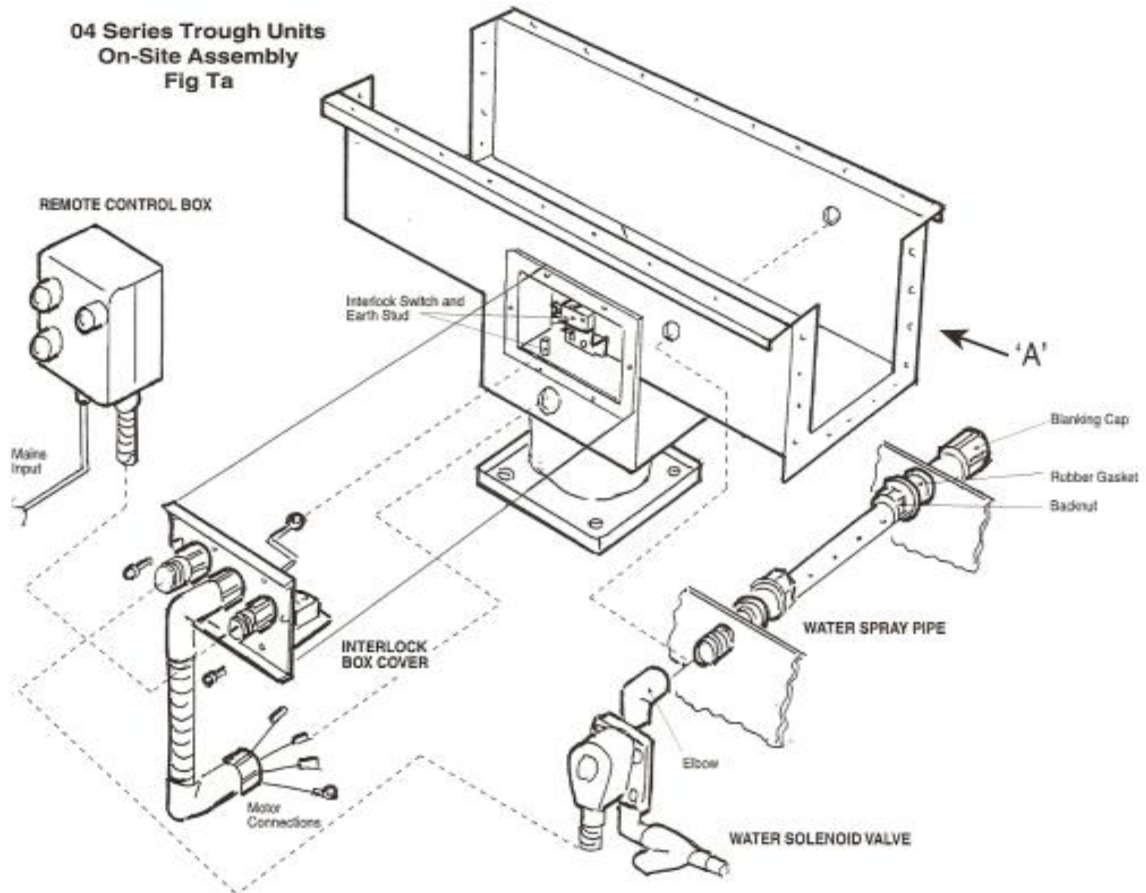

**View on arrow 'A'  
showing 904 flange details**

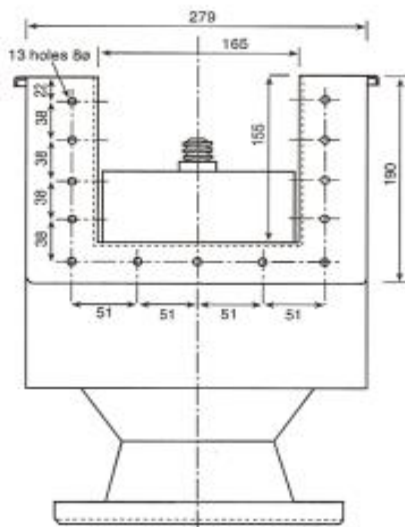

**View on arrow 'A'  
showing 1204 and 1604 flange details**

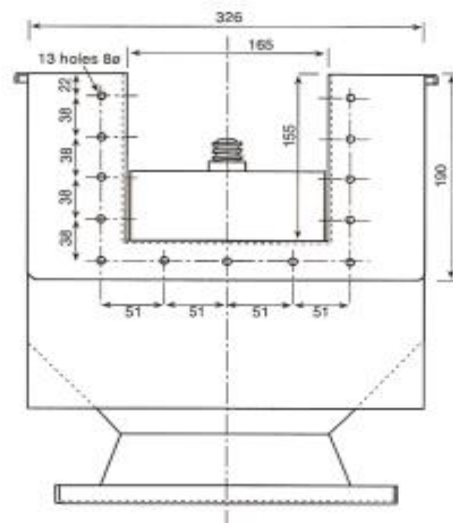

# WIRING DIAGRAM FIG Tb – TROUGH UNITS - SINGLE PHASE –

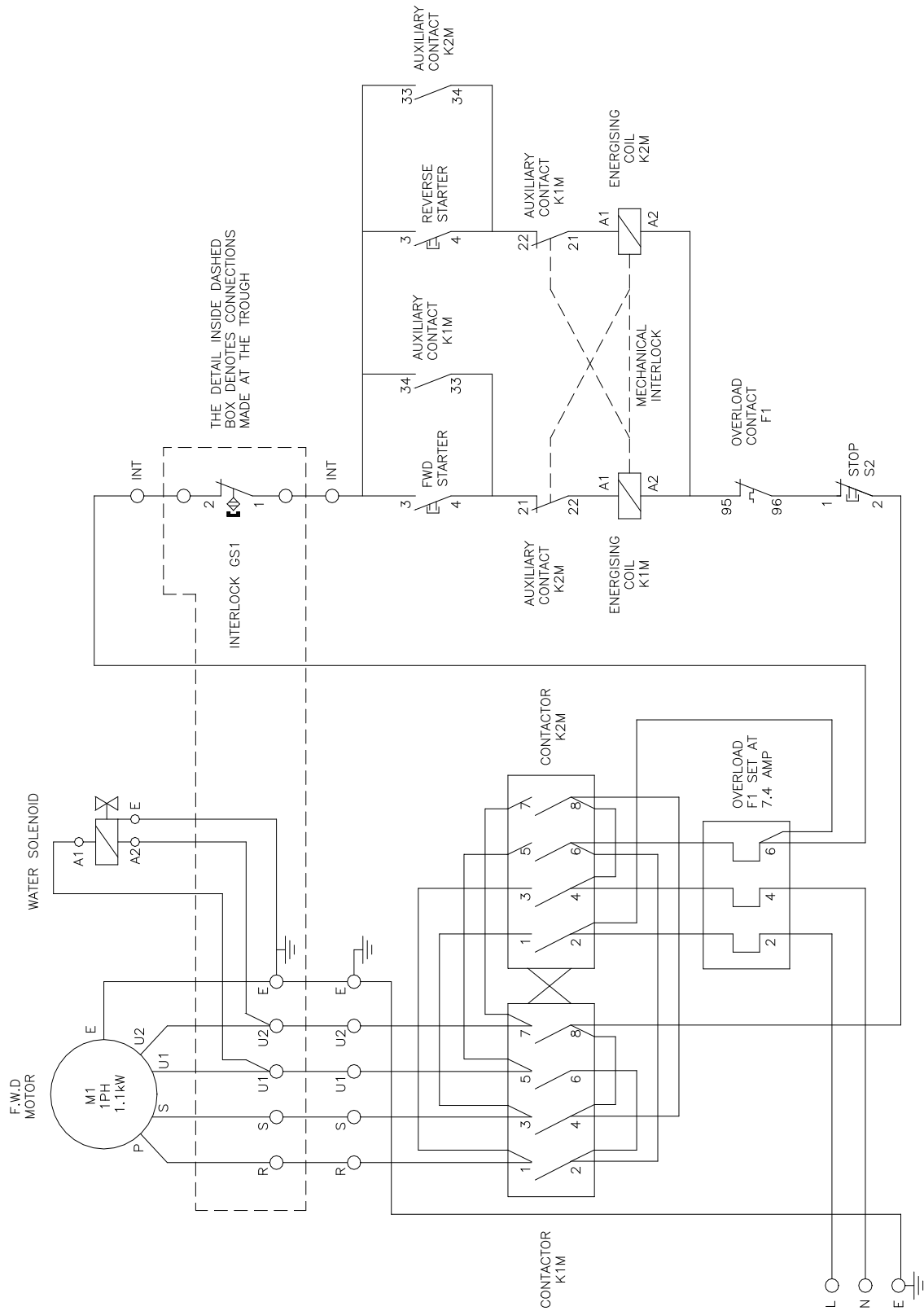

# WIRING DIAGRAM FIG Tc – TROUGH UNITS – THREE PHASE, 4 WIRE

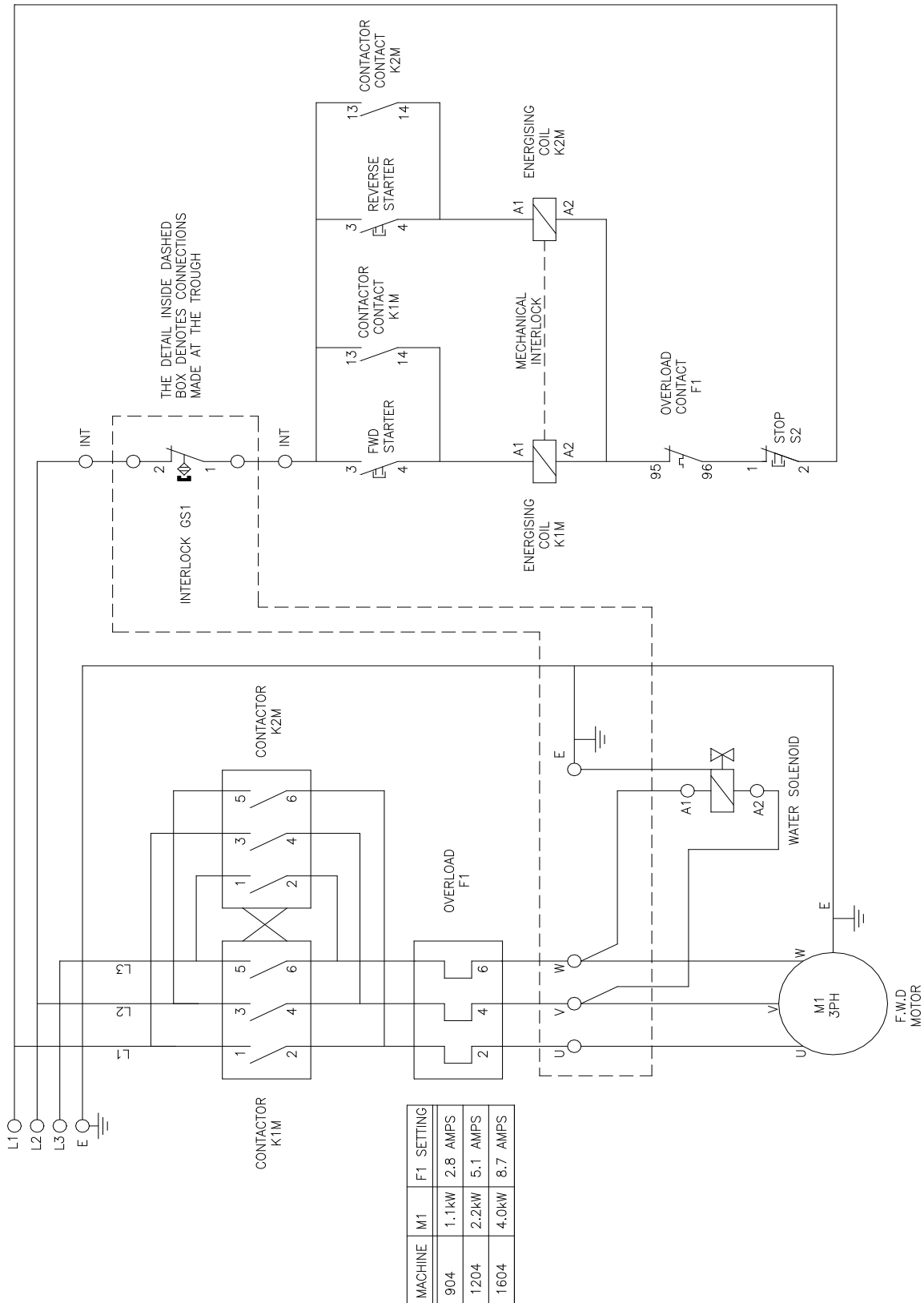

# WIRING DIAGRAM FIG Td – TROUGH UNITS – THREE PHASE, 5 WIRE

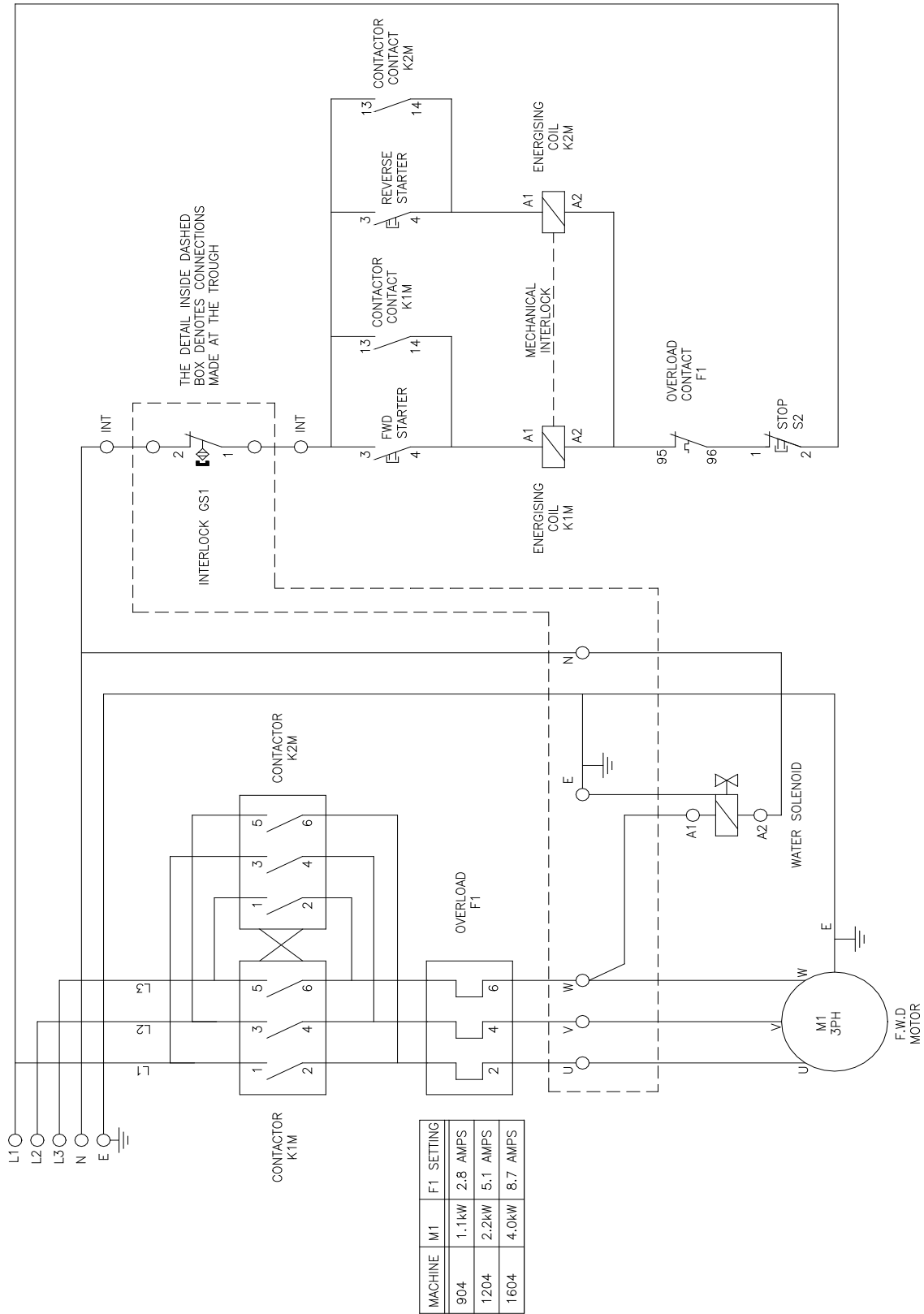



## GUARANTEE

This unit carries a comprehensive UK mainland 2 year warranty. The guarantee is in addition to, and does not diminish your statutory or legal rights.

The guarantee does not cover:

- Accidental damage, misuse or use not in accordance with the manufacturer's instructions.
- Consumable items (such as filters, glass, bulbs, slot toaster elements and door seals.)
- Damage due to incorrect installation, modification, unauthorised service work or damage due to scale, food debris build-up, etc.

The manufacturer disclaims any liability for incidental, or consequential damages.

Attendance is based on reasonable access to the appliance to allow the authorised technician to carry out the warranty work.

Service calls to equipment under warranty will be carried out in accordance with the conditions of sale. Unless otherwise specified, a maximum of 15 minutes of administrative time, not spent directly carrying out servicing work, is provided for within the warranty. Any requirement for staff attending the call to spend greater time than 15 minutes due to administrative requirements, such as on health and safety risk assessments, will be chargeable at the prevailing rate.

## SERVICE INFORMATION

For help with the installation, maintenance and use of your **Lincat** equipment, please contact our service department:

**☎ UK: 01522 875520**

For non-UK customers, please contact your local Lincat dealer

All service work, other than routine cleaning should be carried out by one of our authorised service agents. We cannot accept responsibility for work carried out by other persons.

To ensure your service enquiry is handled as efficiently as possible, please tell us:

- Brief details of the problem
  - Product code
  - Type number
  - Serial number
- } All available on serial plate

Lincat reserve the right to carry out any work under warranty, given reasonable access to the appliance, during normal working hours, Monday to Friday, 08:30 to 17:00.