

Lincat

Installation, Operating, Servicing and Conversion Instructions

Opus 800 Gas Open Top Oven Ranges OG8002-A003

Please make a note of your product details for
future use:

Date Purchased: _____

Model Number: _____

Serial Number: _____

Dealer: _____

Opus **800**

CONTENTS

Important Information	2
Warnings and Precautions	3
Technical Data	4
Checklist of Enclosures	5
Installation	6-7
User Instruction	8-9
Cleaning	10-12
Servicing and Maintenance	13
Component Replacement	14-15
Conversion	16-17
Fault Finding	18
Spare Parts List	19
Accessories	20
Service Information and Guarantee	21

IMPORTANT INFORMATION



Read these instructions carefully before using this product, paying particular attention to all sections that carry warning symbols, caution symbols and notices. Ensure that these are understood at all times.



WARNING!

This symbol is used whenever there is a risk of personal injury.



CAUTION!

This symbol is used whenever there is a risk of damaging your Lincat product.

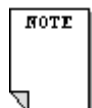

NOTE:

This symbol is used to provide additional information, hints and tips.

KEEP THIS MANUAL FOR FUTURE REFERENCE

WARNINGS AND PRECAUTIONS

It is mandatory that all appliances are installed, commissioned and serviced by a qualified and competent person as defined by the regulations in force in the country of installation.

Failure to comply will invalidate the warranty.



WARNING!

This appliance must be installed by a competent installation engineer in accordance with the installation instructions, and should conform to the following requirements:

Do not obstruct or block the appliance flue.

Installation must include sufficient ventilation to prevent the occurrence of unacceptable concentrations of substances harmful to health in the room in which they are installed.

It is recommended that this appliance is sited under an extraction canopy for the removal of combustion products

After operation, some parts of the appliance will remain hot for a period of time. Please take care to avoid accidental burns.



CAUTION!

All equipment must be earthed to prevent shock.

Do not connect directly to any flue, ducting or mechanical extraction system.

Installation should allow for a sufficient flow of fresh air for gas combustion.

Parts which have been protected by the manufacturer or his agent must not be adjusted by the installer or user.

TECHNICAL DATA

Model	OG8002
--------------	---------------

Dimensions	
Height (mm)	900
Width (mm)	900
Depth (mm)	800
Weight (kg)	138
Hob Cooking Surface w x d (mm)	900 x 600
Useable Oven Capacity w x d x h (mm)	715 x 540 x 400
Oven Shelf w x d (mm)	715 x 540

Connection and Operating Pressures Pressuresimensions	
Gas Inlet Connection	$\frac{3}{4}$ " BSP (Rp $\frac{3}{4}$)
Supply Pressure – Natural G20	20mbar
Supply Pressure – Natural G25	25mbar
Supply Pressure – Propane G31	37mbar

Heat Input (Gross)	
Total - Natural – G20	55.0kW
Total - Natural – G25	50.5kW
Total - Propane – G31	50.5kW
Oven - Natural – G20	10.0kW
Oven - Natural – G25	9.1kW
Oven - Propane – G31	8.5kW
Hob Burner - Natural – G20	7.5kW
Hob Low – Natural – G20	2.2kW
Hob Burner - Natural – G25	6.9kW
Hob Low – Natural – G25	2.1kW
Hob Burner – Propane – G31	7.0kW
Hob Low – Propane – G31	2.2kW

Gas Consumption	
Total – Natural - G20	5.24 m ³ h ⁻¹
Total – Natural - G25	5.60 m ³ h ⁻¹
Total – Propane – G31	3.61 kg h ⁻¹
Hob burner – Natural – G20	0.71 m ³ h ⁻¹
Hob burner – Natural – G25	0.76 m ³ h ⁻¹
Hob burner – Propane – G31	0.50 kg h ⁻¹
Oven burner – Natural – G20	0.95 m ³ h ⁻¹
Oven burner – Propane – G31	0.61 kg h ⁻¹

Oven Temperature Range	$\approx 120 - 280$ °C
-------------------------------	------------------------

CHECK LIST OF ENCLOSURES

Model	OG8002	Tick
Warranty card	1	
Instructions manual	1	
Pan Supports	6	
Oven Shelves	2	

SERIAL NUMBER



Each appliance manufactured at Lincat has a unique identifying number found in the top right hand corner of the data plate attached at the rear of the appliance. Please record that number in the space provided should it be required for future reference.

Serial Number	
---------------	--

INSTALLATION

Site this appliance beneath an extraction canopy for the removal of combustion products.

When making the gas connection, fit an isolating cock into the supply line close to the appliance for emergency shutdown or servicing purposes.



Installation must include sufficient ventilation to prevent the occurrence of unacceptable concentrations of substances harmful to health in the room of installation. There must be a minimum free area of 4.5cm² per kW of total heat input.

Allow for a sufficient flow of fresh air for complete gas combustion.

Do not connect directly to any flue, ducting or mechanical extraction system.

The gas supply hose or tubing shall comply with national requirements in force and shall be periodically examined and replaced as necessary.



An equipotential bonding terminal is provided to allow cross bonding with other equipment.

Install this appliance on a level surface ensuring all vents are unobstructed.

Any partitions, walls or furniture must be of non-combustible material.

Minimum distances = A, 50mm B, 1000mm – see Fig 1.

If this appliance is fitted with castors, use caution at all times when manipulating or moving, and lock castors when appliance is in position.

ACCESS THROUGH NARROW DOORWAYS

The overall depth of the appliance (including door handles) is **825mm**.

This can be reduced further to an overall depth of **750mm** by the following steps.

1. Remove the pan supports, pan support dividers, burner caps and oven shelves.
2. Using the cardboard packaging lay the appliance on its back in the cardboard cap.
3. Remove the castors both front and back.
4. The appliance width will be reduced to **750mm** sufficient to pass through a standard doorway of **770mm**.

Reassemble all parts when clearance is completed.

For doorways that are narrower the appliance can be split. Details are available on request from the manufacturer.

SITING

The installer must ensure that all regulations are met and that there is an unobstructed minimum distance of 1000mm from the top of the flue to the ceiling, which must be of non-combustible material.

The appliance should be installed on a level surface ensuring the unit is stable and firmly located.

Any partitions, walls or kitchen furniture in close proximity must be of non-combustible materials and not be closer than 50mm from the sides and rear of the flue.

The Installer shall pay particular attention, in order not to disturb the air combustion admission nor the combustion products evacuation of appliances fitted with open burners.

GAS SUPPLY AND CONNECTION

- Connection is at the rear of the unit via a Rp 3/4" (3/4" BSP)
- Connection shall comply with local regulations.
- The hose shall be periodically examined and replaced as necessary.
- When making the connection to the appliance an isolating cock should be fitted into the supply line close to the unit, for emergency shutdown or servicing purposes.



An equipotential bonding terminal is provided to allow cross bonding with other equipment.

The above listed appliance has been designated Cat I & Cat II for 2nd and 3rd family gases, flue type A₁

SUPPLY PRESSURES

The appliance is connected directly to the gas supply where the gas supply pressure is controlled at the source of inlet in the building or via the governor attached to the bottle gases. See Technical Data for the supply pressures.

- To gain access to the gas pressure test nipple the fascia panel requires removal (see page 6). The test nipple is situated in the centre of the manifold rail.
- Remove the blanking screw and attach a pressure gauge to the boss of the test nipple.
- Light the oven burner and set thermostat to the highest setting and check the pressure.

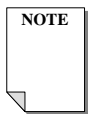

For those destination countries where the supply pressure exceeds the supply pressures given in the Technical Data above a regulator must be fitted and the supply pressure set to the pressures detailed.

LOCKING OF WHEELS

When the appliance has been installed in its intended position the front castors should be locked by depressing the locking tabs on the castors.

Locks should only be released for the intention of moving the appliance for cleaning purposes and/or routine servicing of the appliance.

USER INSTRUCTION

APPLIANCE USE

This appliance is only for professional use and should only be used by qualified personnel. Ensure that the person responsible understands how to light, safely operate, clean and shutdown the appliance and is made aware of the position and operation of the gas isolating cock in the event of an emergency.

Ensure that all controls have free and easy movement, if not contact a qualified service engineer.

This appliance hob is intended to be used for heating of culinary preparations that can be cooked by means of frying, simmering or boiling in suitable pans and **MUST NOT** be used for any other purpose.

The oven cavity is intended for the cooking of culinary preparations by means of braising, roasting and baking either directly on the oven shelves or in suitable none combustible containers approved for containing food products. The oven **MUST NOT** be used for any other purpose.

Operators of the appliance must not leave combustible materials directly in the cooking areas of the appliance when in use.

Ensure the pan supports are centrally placed on the hob to.

It is recommended that a burner is lit first before placing large pans over the burner.



It is not recommended that multiple lit hob burners are covered at any one time by large gastronome pans or detachable griddle plates.

PAN PLACEMENT

Pans should be placed centrally on the pan support in relation to the burner for maximum efficiency.

PAN SIZES

The recommended pan base diameters are no smaller than 150mm and no larger than 400mm.

Pans should never be placed in such a position that they become a hazard from tipping

OPERATION OF THE APPLIANCE

- The appliance should not be left unattended when in use for any lengthy period of time.
- Pans should only be filled to a level no more than to prevent a boil over situation.
- Periodically inspect liquid volumes to prevent a boil dry situation.
- Frying of product should never be left unattended.
- Use hand and arm protective when handling hot pans to avoid injuries from burns.

LIGHTING SEQUENCE

Please ensure that the gas isolation valve for the appliance is turned to the open position before attempting to light this unit.

HOB BURNERS

From the OFF position: press and turn the control knob anti-clockwise to any position between the two stylized flames to allow gas through to the burner.

Maintaining the control knob depressed, manually light the gas at the burner using a taper or piezo ignitor wand.

On establishing a flame at the burner, keep the knob depressed for approximately 15 seconds then release. The burner should remain lit.

If the appliance has stood unused for any length of time it may be necessary to purge the burner feed pipes of air. To purge the burner feed pipes of air depress and rotate a control knob to the full on position. Maintain the knob in the depressed position for 20- 30seconds and then light the gas at the burner. Repeat as necessary until the gas ignites.

OVEN BURNER

Open the oven door/s

From the OFF position press and turn the oven thermostat knob anti-clockwise to the stylized star position to allow gas to flow through to the oven burner.

Maintaining the control knob depressed, push the oven ignitor button until an audible click is heard. A spark will be generated at the oven burner. The gas at the oven burner should light. It may be necessary to repeat the ignition process a number of times until the gas lights.

On establishing the flame at the oven burner, maintain the thermostat knob in a depressed state for approximately 15 seconds and then release the control knob. The gas should remain lit.

Rotate the thermostat knob to the desired temperature setting.

OVEN TEMPERATURES

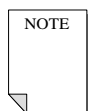

The temperatures on the thermostat knob are a guide and generally reflect the temperature at the centre of the oven. The temperatures in the oven will vary from top to bottom. It may be necessary to periodically rotate product being cooked to ensure even cooking.

OPERATION OF THE APPLIANCE

- The appliance should not be left unattended when in use for any lengthy period of time.
- Pans should only be filled to a level no more than to prevent a boil over situation.
- Periodically inspect liquid volumes to prevent a boil dry situation.
- Frying of product should never be left unattended.
- Use hand and arm protective when handling hot pans to avoid injuries from burns.

OVEN DOORS



Care must be taken when opening the oven doors when the appliance is in operation due to the rapid escape of hot air.

Use hand and arm protective when handling hot roasting pans and baking trays to avoid injuries from burns.

SHUT DOWN

To shut down the appliance rotate all control knobs clockwise to the OFF position. The gas supply stopcock or bottle valve should now be closed.

CLEANING



Do not use a water jet or steam cleaner, and do not immerse this appliance. Clean all panels with warm water and mild detergent, do not use abrasive materials. Dry with a soft cloth.

It is important that users of the appliance systematically check and clean down as necessary areas of the hob and oven cavity that have accumulated oils, fats and other combustible debris from previous cooking. Particular attention must be paid to the burner head ports. Ensure they are always clear. Ensure the appliance and all its parts are in a cold state before commencing any cleaning routine.

Areas to Check

- **BURNER CAPS** – Check burner caps are clean and centrally seated on the burner head
- **BURNER HEADS** – The burner heads must be fitted correctly to function properly.
- **PAN SUPPORTS** – The pan supports are manufactured from cast iron and are heavy. For ease of cleaning they can be removed from the appliance and placed in a suitable dish washer.
- **OVEN SHELVES** – The shelves can easily be removed for routine cleaning. Stubborn burned on deposits can be cleaned using suitable approved cleaning agents and scourers
- **OVEN BASE TRAY** – Can be easily removed for cleaning
- **OVEN CAVITY** – To clean the oven cavity remove the shelves and base tray and remove any solids and accumulated fats, oils and spillages.

Hob Components.

Pan Supports – Remove from the appliance, taking careful note of the orientation of the locating feet which **must** always be fitted with the feet to the sides (left & right) of the appliance.

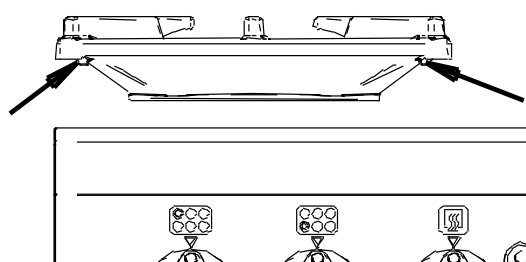
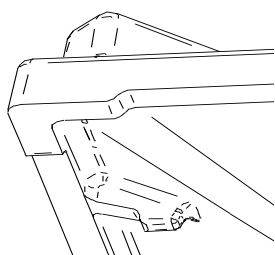

The Pan Supports can be cleaned with a mild detergent and hot water solution using a soft bristled brush. Rinse and dry thoroughly with a dry cloth.

Burner Cap – Remove from the appliance taking care not to damage the thermocouple which protrudes from the support.

Hob Burner Components	
Part	Description
G	Burner Cap

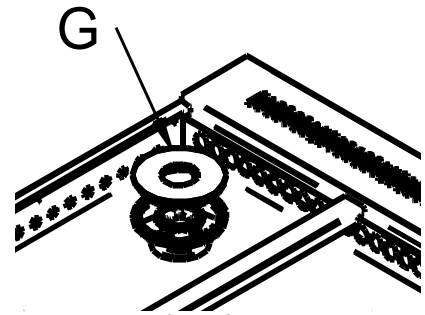

Pan Support Channel – Remove from the appliance taking note of its fixing points.

Hob Burner Components	
Part	Description
H	Pan Support Channel

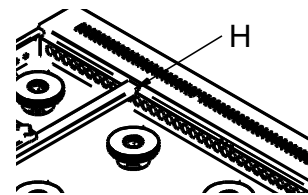

The Pan Support Channel can be cleaned with a mild detergent and hot water solution using a soft bristled brush. Rinse and dry thoroughly with a dry cloth.

Oven Shelves & Side Hangers – Open the oven doors and remove the shelves and hangers.

To remove shelves, tilt up the rear and slide shelf forward.

To remove side hanger, lift hanger up and then pull into centre of oven.

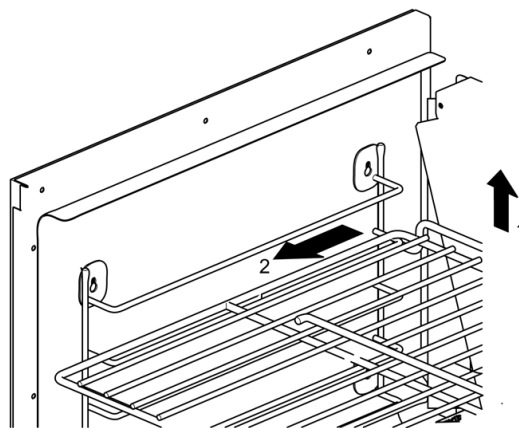

The Shelves and Side Hangers can be cleaned with a mild detergent and hot water solution using a soft bristled brush. For stubborn deposits a de-greasing agent may be used.

Rinse and dry thoroughly with a dry cloth.

Oven Drip Tray - Open the oven doors and remove the drip tray **P** from the appliance.

The Oven Drip Tray can be cleaned with a mild detergent and hot water solution using a soft bristled brush. For stubborn deposits a de-greasing agent may be used.

Rinse and dry thoroughly with a dry cloth.

Oven Compartment – Open the oven doors and leave the drip tray **P** in situ.

Oven Components	
Part	Description
N	Thermostat Phial
P	Oven Drip Tray



The sides, top and back panels can be cleaned with a mild detergent and hot water solution using a soft bristled brush. For stubborn deposits a de-greasing agent may be used.

Rinse and dry thoroughly with a dry cloth.

Take care not to disturb the burner components or the thermostat phial **N**.

SERVICING AND MAINTENANCE

All servicing, maintenance and component replacement on this appliance should be carried out by one of our recommended service engineers.

SERVICE ACCESS

To access and service the gas control valves

- Remove the control knobs **D** and fascia panel **C** to gain access to the valves.
- Remove the two fixing screws **EE** securing the valve boss and carefully withdraw the spindle from the valve.
- Grease as necessary and refit parts. Carry out gas soundness check.

FACIA PANEL REMOVAL

- Open oven door.
- Remove control knobs **D**.
- Undo the three fascia fixings screws **E**.
- Remove the fascia panel **C**.

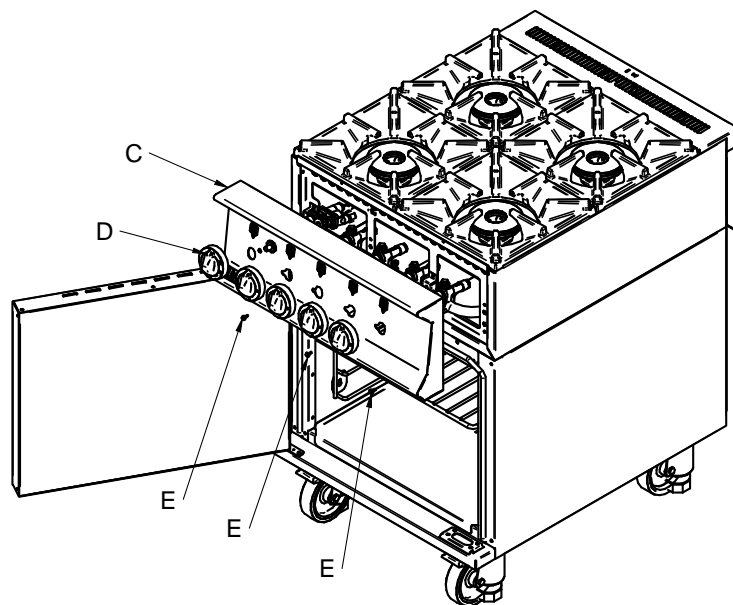

Model shown OG8001

OPERATIONAL CHECK

Commissioning must include an operational check of all controls.

- Check that each burner can be lit at both full rate and low rate.
- Check that each burner will remain lit when turned to low rate.

Servicing of Hob Valves and Oven Thermostat - **SERVICING RECOMMENDED EVERY 6 MONTHS**

To service the valve and or thermostat carefully remove the niting cap screws and withdraw the spindle from the valve

Clean old grease and re-grease with suitable gas compliant compound

Re-assemble and perform soundness check

COMPONENT REPLACEMENT

Hob Thermocouple

Remove the control knobs **D**, pan supports **F** and fascia panel **C**.

Remove the top thermocouple lock nut.

Remove thermocouple nut from valve body **BB**.

Withdraw the thermocouple.

Fit the new thermocouple and re-assemble in the reverse order.

Oven Thermocouple

Remove the control knobs **D** and fascia panel **C**.

Remove the thermocouple nut from the thermostat body **FF**.

From the rear of the appliance remove the lower back panel.

Remove the thermocouple lock nut **V** from the burner **U** and withdraw the thermocouple **T**.

Re-assemble in the reverse order.

Control Valve

Remove the control knobs **D** and fascia panel **C**.

Remove the nut from the gas output at the valve.

Remove the thermocouple nut from the valve.

Remove clamp screw **DD** from the valve.

Free the valve from the manifold **AA**.

Fit the new valve and re-assemble reverse order.

Perform gas soundness test of circuit prior to operation of appliance

Oven Thermostat

Remove the control knobs **D** and fascia panel **C**.

Remove the nut from the gas output at the thermostat.

Remove the thermocouple nut from the thermostat.

Remove clamp screws **DD** from the thermostat **FF**.

Remove the file cover plate from the surround.

Free the thermostat bulb from the oven bracket and feed through the oven liner.

Free the thermostat from the manifold **AA**.

Fit the new thermostat and re-assemble reverse order.

Perform gas soundness test of circuit prior to operation of appliance.

Hob Burner

Remove the control knobs **D**, pan supports **F** and fascia panel **C**.

From the front of the unit undo fixing screws **JJ**.

Remove grub screws **MM** and withdraw injector housing **KK**.

Fit the new burner body and re-assemble parts.

Oven Burner

Remove the oven base tray **P** and shelves.

Disconnect the ignition lead and remove thermocouple **V** by undoing lock nut **U**.

Undo the flexi hose from the coupling **R** and remove coupling **R** from burner.

Undo four fixing screws and remove burner.

Re-assemble in reverse order.

Perform gas soundness test of circuit prior to operation of appliance.

Oven Ignitor Electrode

Remove the oven shelves.

Remove the ignitor lead at the ignitor.

Remove the ignitor retaining screw and nut.

Replace the ignitor.

Check that the ignitor is replaced correctly and ignites the pilot flame upon operation.

Piezo Ignitor

Remove facia panel **C**.

Disconnect the ignitor and ignitor earth leads.

Remove the retaining nut and withdraw from unit.

Replace and fit in reverse order.

Doors

Open doors and undo the two lower hinge fixing screws (see page 6).

Pull door away together with lower hinge.

Replace and fit in reverse order.

CONVERSION

Conversion of Gas Type Injector Changes

Model	Gas	Inlet Pressure	Injector	Ø	Mark	Part No.
OG8002	G20	20 mbar	LL	1.96	196	JE273 x 6
			CC	1.10	11	JE275 x 6
	G25	25 mbar	S	2.30	740	JE28 x 1
			GG	0.74	74	JE250 x 1
OG8002	G31	37 mbar	LL	1.34	134	JE281 x 6
			CC	0.74	74	JE250 x 6
			S	1.51	310	JE45 x 1
			GG	0.51	51	JE251 x 1

Hob Valve Bypass Injectors

- Remove fascia panel (see page 6).
- Remove the bypass injectors **CC** from each of the hob burner control valves **BB**.
- Replace the bypass injectors applicable to the required gas type. Screw fully home, but do not over tighten.

Hob Tap Components	
Part	Description
AA	Manifold
BB	Gas tap
CC	Bypass injector
DD	Clamp screw

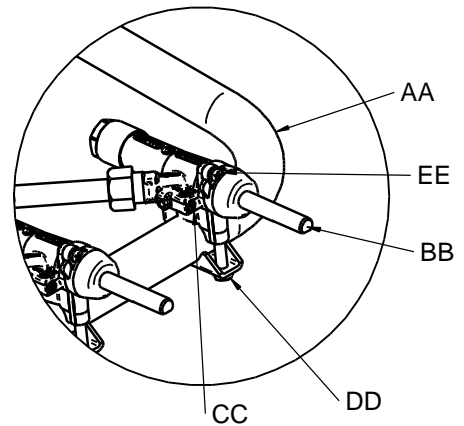

Hob Burner Injectors

- From the front of the unit undo fixing screws **JJ**.
- Remove grub screws **MM**, and withdraw injector housing **KK**.
- Replace injector applicable to gas type.
- Repeat the procedure for remaining hob burners.

Hob Burner Components	
Part	Description
HH	Feed pipe
JJ	Fixing screws
KK	Injector housing
LL	Injector
MM	Grub screw

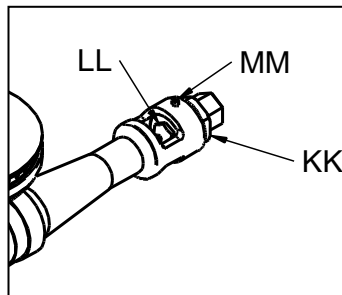
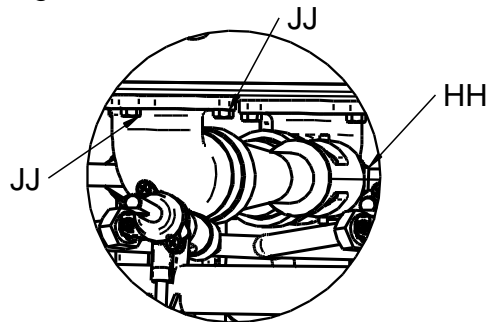

Oven Thermostat Bypass Injector

- Remove the bypass injector **GG** from the oven thermostat valve **FF**.
- Replace the bypass injectors applicable to the required gas type. Screw fully home but do not over tighten.
- Re-fit the igniter lead, fascia panel **F** and control knobs **D**.

Oven Thermostat Components	
Part	Description
AA	Manifold
FF	Thermostat
GG	Bypass injector

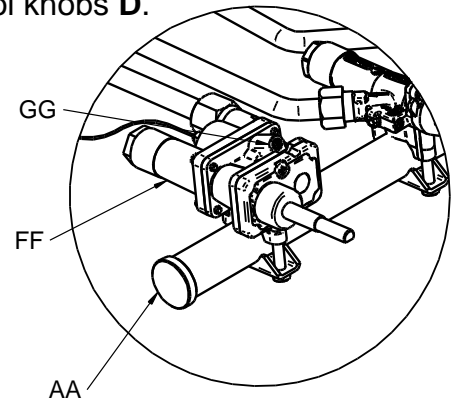

Oven Burner injector

- Remove the oven base tray and shelves.
- Disconnect the ignition lead and remove thermocouple **V** by undoing lock nut **U**.
- Undo the flexi hose from the coupling **R** and remove coupling **O** from burner.
- Remove the injector, fibre washer **Q** and copper washer **S**.
- Replace the injector applicable to the required gas type including the new washers supplied.
- Re-fit all components in reverse order.

Oven Burner Components	
Part	Description
Q	Fibre Washer
R	Coupling
S	Copper washer
T	Injector
U	Thermocouple Nut
V	Thermocouple
W	Burner
X	Ignitor electrode

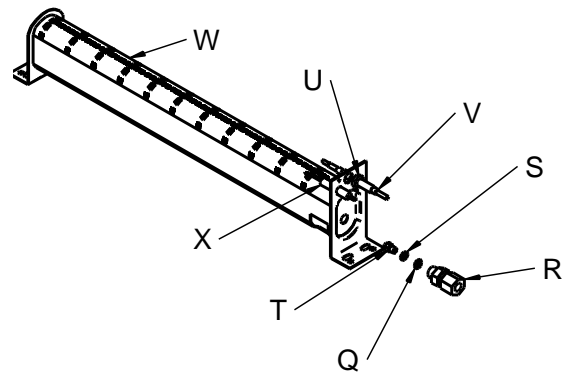

Completion of Conversion

- Remove the redundant data plate and gas type identification label and attach new replacements, corresponding to new gas type.
- Test all previously dismantled joints for soundness.
- Functionally operate the appliance (see page 9) to the new operating pressure as detailed on page 14.

Aeration Adjustment

To set the aeration at the venturi relevant to the gas type

Remove the retaining screw.

Slide the aeration sleeve **HH** to the applicable gas type.

Secure the aeration sleeve

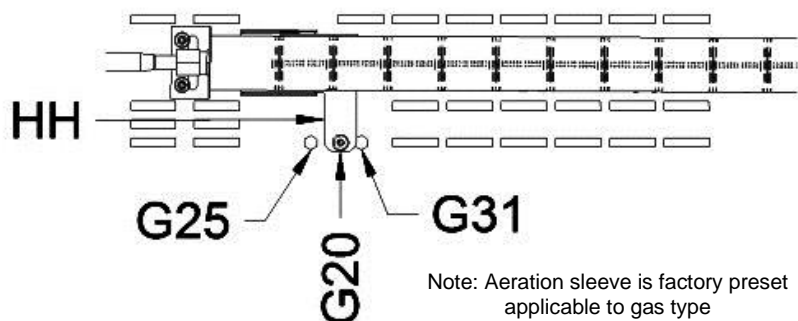

Note: Aeration sleeve is factory preset applicable to gas type

FAULT FINDING

Please refer to the Service Help Desk number on the final page of this manual.

- Piezo oven ignitor not sparking.

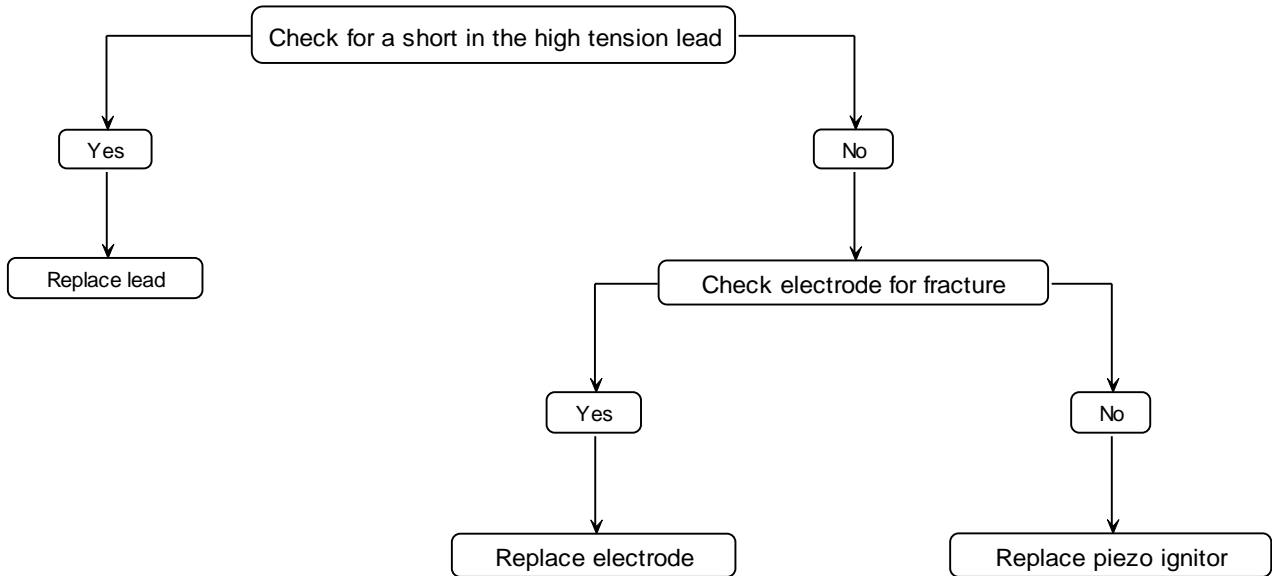

- Burner/s will not light or stay lit

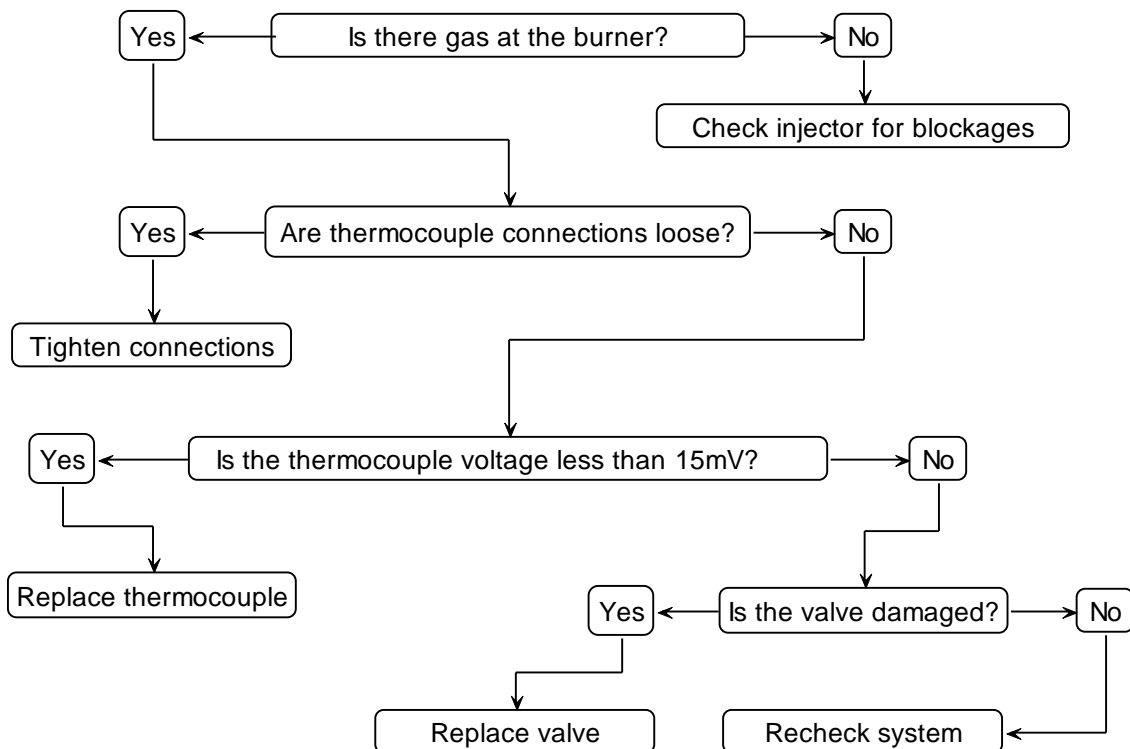

SPARE PARTS LIST

Part number	Part description	OG8002
BU55	Door bush	4
BU78	Oven burner	1
BU103	Burner cap	6
BU104	Burner body	6
BU106	Injector housing	6
BU107	Elbow	6
BU108	Venturi	6
CO113	Copper Washer	1
CA143	125mm braked swivel castors	2
CA145	125mm un-braked swivel castors	2
DO211	Door catch assembly	2
HA77	Door handle	2
IG16	Ignitor electrode	1
IG18	Ignition lead	1
IG35	Ignitor piezo	1
IG37	Ignitor piezo earth lead	1
JE28	Oven burner injector – Natural	1
JE45	Oven burner injector – Propane	1
JE273	Hob burner injector – Natural	6
JE281	Hob burner injector – Propane	6
JE275	Hob valve low rate jet - Natural	6
JE250	Hob valve low rate jet – Propane	6
JE250	Oven thermostat low rate jet - Natural	1
JE251	Oven thermostat low rate jet - Propane	1
KN503	Control knob – Hob burners	6
KN504	Control knob – Oven thermostat	1
LE37	Adjustable leg - 150mm	4
PA160	Cast pan supports	6
SE25	Door seal	2m
SH113	Oven shelf	2
SP83	Leg spanner	1
SR08	Oven side rack	2
TC30	Thermocouple (oven)	1
TC50	Thermocouple (hob top)	6
TH201	Oven thermostat	1
VA74	Hob burner valve	6
WA08	Fibre Washer (oven burner jet)	1

ACCESSORIES

Part Number	Description	Used on
OA8902	Splashback/Shelf	

SERVICE INFORMATION

For help with the installation, maintenance and use of your **Lincat** equipment, please contact our service department:

☎ UK: 01522 875520

For non-UK customers, please contact your local Lincat dealer

All service work, other than routine cleaning **MUST** be carried out by qualified personnel and a record kept of any remedial actions taken and at least cover the requirements of the service schedule of this document. We cannot accept responsibility for work carried out by other persons.

To ensure your service enquiry is handled as efficiently as possible, please tell us:

- Brief details of the problem
 - Product code
 - Type number
 - Serial number
- } All available on serial plate

Lincat reserve the right to carry out any work under warranty, given reasonable access to the appliance, during normal working hours, Monday to Friday, 08:30 to 17:00.

DECLARATION

All Lincat products capable of burning gaseous fuels, satisfy the requirements of the Gas Appliance Regulations 2016/426.

GUARANTEE

This unit carries a comprehensive UK mainland warranty. The guarantee is in addition to, and does not diminish your statutory or legal rights. Contact Lincat for terms and conditions

The guarantee does not cover:

- Accidental damage, misuse or use not in accordance with the manufacturer's instructions
- Consumable items (such as filters, glass, bulbs, slot toaster elements and door seals.)
- Damage due to incorrect installation, modification, unauthorised service work or damage due to scale, food debris build-up, etc.

The manufacturer disclaims any liability for incidental, or consequential damages. Attendance is based on reasonable access to the appliance to allow the authorised personnel to carry out the warranty work.

Service calls to equipment under warranty will be carried out in accordance with the conditions of sale. Unless otherwise specified, a maximum of 15 minutes of administrative time, not spent directly carrying out servicing work, is provided for within the warranty. Any requirement for staff attending the call to spend greater time than 15 minutes due to administrative requirements, such as on health and safety risk assessments, will be chargeable at the prevailing rate.

For Information

