



IMC VULTURE 904X FLOOR-MOUNTED FOOD WASTE DISPOSER - 3 PHASE [4 WIRE] [AIR BREAK] - W 438 MM - 1.1 KW

MODEL: F54/733



Fast and efficient, the 904X Waste Disposer with airbreak is able to dispose of 500kg of food waste per hour and handles up to 1000 covers per sitting, making it ideal for larger hotels, hospitals, universities, prisons and food preparation companies.

An advanced version of the 904 model, the 904X is able to switch itself off to save energy and has an automatic rinse function, to prevent nasty odours.

It is suitable for medium waste - plate waste, vegetables and peelings, meat and fish scraps, and small bones. The free-standing unit can be welded into tabling with a E30/095 hopper rim, for quick

PRODUCT FEATURES

- Fast and efficient disposal of up to 500kg of food waste per hour.
- Handles up to 1000 covers per sitting - ideal for large kitchens.
- For medium waste (plate waste, vegetables and peelings, meat and fish scraps).
- Free-standing design, but can be welded into tabling with E30/095 hopper rim.
- Manually reversible motor to extend operational life.
- Low-load cut-outs ensure energy and water efficiency.
- With class A airbreak kit - recommended when connecting to a mains water supply.
- Suitable for large kitchens with three-phase, four-wire power supply.

A/A FILE NUMBER:

ITEM NUMBER:



IMC VULTURE 904X FLOOR-MOUNTED FOOD WASTE DISPOSER - 3 PHASE [4 WIRE] [AIR BREAK] - W 438 MM - 1.1 KW

MODEL: F54/733

WEIGHTS & DIMENSIONS

Width	438 mil
Depth	564 mil
Height	942 mil
Weight	51.5 kg

SHIPPING DETAILS

Ship Width	62 cm
Ship Depth	48 cm
Ship Height	104 cm
Ship Weight	56.65 kg
Number of Shipment Parcels	1
Ship Method	Small Parcel (FedEx, UPS, DHL)
Shipping Origin Zip Code	LN6 3QZ, UNITED KINGDOM
Quick Ship Product	No

PRODUCT CERTIFICATIONS



ENERGY SPECS

Primary Energy Type	Electric	Number of Electrical Plugs	Not Applicable
Electrical Total Amperage	2.8 A	Electrical Connection Type	Direct Hardwired
Electrical Volts	400V	Number of Electrical Conductor Wires	1
Electrical Total Wattage	1100 W	Dedicated Circuit Required	Yes
Electrical Kilowatts	1.1 kW	Electrical Remarks	Three
Electrical Phase	3-Phase	Energy Saving	No
Electrical Plug Type	Hardwired		

ADDITIONAL SPECIFICATIONS

Airbreak	Yes
Control Type	On/Off
Meal Waste Servings Processed Per Sitting	1000
Motor Power	1.5 hp
Operator Safety Method	Interlock
Self-Cleaning Capable	No
Waste Processing Capacity Per Hour: Weight	500 kg
Waste Types Processed	Medium (small pork/chicken bones, vegetables and fruit)

IMC reserves the right to modify specifications or discontinue models without incurring obligation. Dimensions nominal.

Document Auto-Generated
July 02, 2024





IMC VULTURE 904X FLOOR-MOUNTED FOOD WASTE DISPOSER - 3
PHASE [4 WIRE] [AIR BREAK] - W 438 MM - 1.1 KW

MODEL: F54/733

BIDDING SPECIFICATIONS

Bidding Specifications Not Available.

TECHNICAL DRAWING

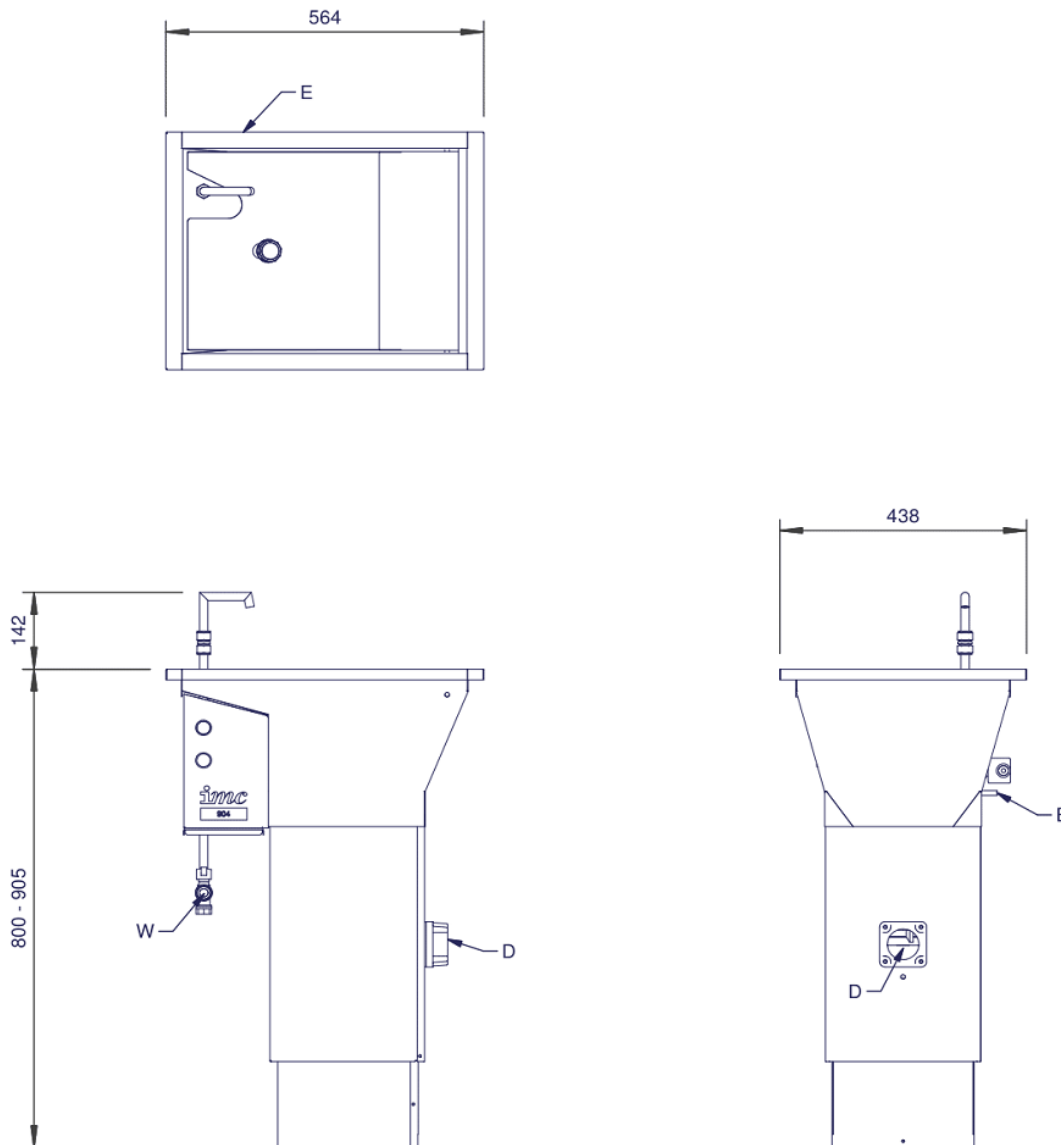

IMC reserves the right to modify specifications or discontinue models without incurring obligation. Dimensions nominal.

Document Auto-Generated
July 02, 2024